



POLY RECEIVER HITCH SPREADER

MODEL: 600P & 1000P

OPERATOR'S MANUAL

**DO NOT USE OR OPERATE THIS EQUIPMENT UNTIL THIS MANUAL
HAS BEEN READ AND THOROUGHLY UNDERSTOOD**

Please visit www.snowplows.hiniker.com to access the most recent version

PART NUMBER 25014940

TABLE OF CONTENTS

25014940

10/23

Hiniker/25014940

TO THE PURCHASER.....	2
SAFETY.....	3-4
OPERATING PROCEDURES	5-9
General Information.....	5
Sander Control Box.....	5
Spread Control	7
Transporting Spreader	7
Spreader Optional Equipment.....	7
Swing Away Kit.....	8
Vibrator Kit.....	8
Storage.....	9
MAINTENANCE & SERVICE PROCEDURES	10
TROUBLE SHOOTING	11
INSTALLATION INSTRUCTIONS	12-14
SPECIFICATIONS.....	15
WARRANTY	17

TO THE PURCHASER

This product is designed and manufactured to give years of dependable service, when properly maintained and used for the purpose for which it is intended. Never allow anyone to operate this equipment until they fully understand the complete contents of this manual. It is the responsibility of owners who do not operate this equipment to ensure the operator is properly instructed and understands the contents of this manual. It is also the owner's responsibility to ensure that anyone operating this equipment is mentally and physically capable of so doing.

Important information is contained in this manual to help ensure safe and efficient operation.

If you have any questions about this manual, or the equipment discussed herein, contact your Hiniker dealer.



This is a safety alert symbol. It alerts an operator to information concerning personal safety. Always observe and heed these instructions, otherwise death, or serious injury can result!

All references to LEFT or RIGHT mean viewing the spreader from the rear and facing the truck.

This Operator's manual is shipped with this equipment. Contact your Hiniker dealer for additional copies.

Always obtain original Hiniker service parts. Substitute parts could adversely affect equipment performance and warranty.

Check that your dealer has forwarded the Hiniker delivery report copy and the machine serial number to maintain maximum service and warranty benefits. This does not put you on any mailing list and information thereon is not available to others.

Your spreader's identification number plate is at the location shown below.

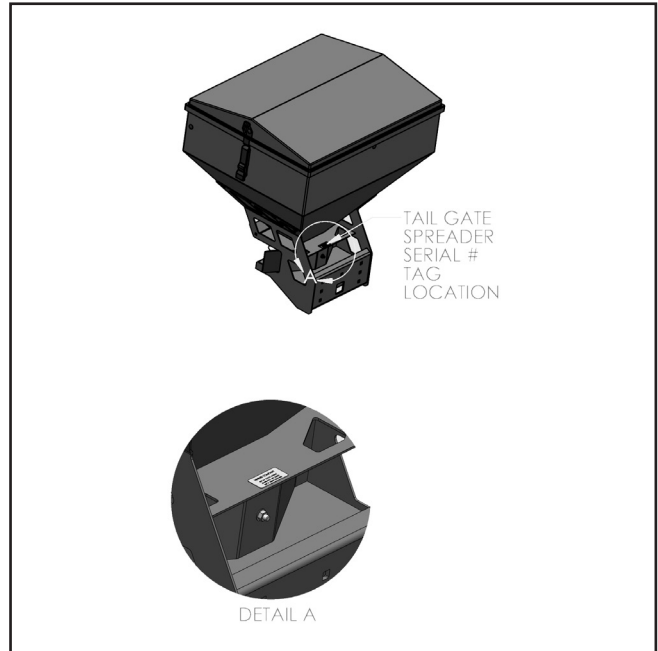

Record the following information for later reference when obtaining service parts:

Purchase Date _____

Purchaser's Name _____

Dealer's Name _____

Machine Serial No. _____

SAFETY



This is a safety alert symbol. It alerts an operator to information concerning personal safety. Always observe and heed these instructions, otherwise death or serious injury can result!

Operator safety is a principle concern in equipment design and distribution. However, many accidents occur because a few seconds of thought, and a more careful approach to handling, were ignored.

Accidents can be avoided by knowing and following the precautions cited in this manual.

GENERAL SAFETY

1. Read this manual thoroughly. Make sure the operator understands it and knows how to operate this equipment safely. This equipment can injure an untrained or careless operator and bystanders. If you sell this equipment, ensure the new owner acknowledges receipt of this manual.
2. Make sure all safety guards are securely mounted in place before operating this spreader.
3. Do not attempt to handle or service this equipment, or direct others to do the same, unless you know how to do it safely and have the proper tools for the job.
4. Keep hands, feet, hair, and clothing away from moving/rotating parts. Flying material can cause bodily injury. Wear eye protection.
5. Do not alter the equipment to the extent of compromising safety or performance.
6. Material to be spread can be dangerous. Improper selection, application, use or handling may be a hazard to persons, vehicle or other property. Follow instructions and precautions given by the material manufacturer.
7. Do not over-load your vehicle beyond payload limits. If there are any questions, contact the vehicle manufacturer.
8. Make sure spreader is securely fastened to vehicle in accordance with this manual.
9. Do not operate a spreader in need of maintenance or repair.

BEFORE OPERATION

1. Discipline yourself to visually check for worn, damaged or cracked parts before starting use. Replace these with genuine Hiniker parts.
2. Check all controls and operating functions of machine in a safe area before starting to work.
3. Do not adjust or clean machine while it is running. After making adjustments, check machine thoroughly for loose parts, hardware and tools.
4. Always disconnect wiring harness before removing or replacing any electrical components.
5. Verify hardware attaching safety cable to cover and hopper is tight.
6. Make sure cover rubber latches are securely fastened before driving motor vehicle.

DURING OPERATION

1. Drive carefully and always wear seat belts when operating a motor vehicle. Braking distance may be increased and handling characteristics impaired due to extra weight of spreader.
2. Ensure everyone is clear of machine, especially away from blind areas of the operator, before starting or operating this equipment.
3. Stay out of hopper when auger power source is engaged. If machine becomes plugged or material bridges, do not attempt to remove blockage until machine has been shut off and auger and spinner movement have stopped.

Use a shovel or other long-handled tool to reach inside hopper. Never attempt to break up material inside hopper with hands or feet.

4. Set brakes and stop truck's engine before adjusting or servicing your spreader.

AFTER OPERATION

1. Inspect spreader for components that have become excessively worn or damaged and must be repaired or replaced.
2. Develop a regular maintenance schedule to ensure safe, dependable spreader operation.
3. Never use swing away hopper feature with material in spreader.
4. Never remove spreader with material in hopper.
5. Disconnect power before servicing equipment.
6. **DO NOT** leave unused material in hopper. Material will freeze up or solidify causing unit to malfunction. Empty and clean after each use.

OPERATING PROCEDURES

GENERAL INFORMATION

Hiniker spreaders are capable of dispersing a variety of dry materials for control of ice on roadways, walkways and parking lots.

Vehicle load carrying capacity limits the maximum load that can be safely transported, which could be less than the volumetric capacity of the spreader. Check the vehicle's load rating certification sticker and DO NOT overload the vehicle beyond its Gross Vehicle Weight Rating (GVWR) or its Gross Axle Weight Rating (GAWR). Check carrying capacity of 2" receiving hitch on vehicle. Be sure not to overload hitch. Overloading could result in an accident or damage to vehicle and spreader.

An alternator rated for 135 amps or higher is recommended.

Use the following tables to calculate vehicle payload when material is loaded in the spreader.

VOLUMETRIC CAPACITY: (Cubic Feet, Approx.)

	LEVEL
Hopper Capacity Model 600P	6
Hopper Capacity Model 1000P	10

WEIGHT: (Pounds, Approx.)

Hopper Assembly Model 600P	120
Hopper Assembly Model 1000P	136

MATERIAL WEIGHTS: (Pounds Per Cubic Feet, Approx)

Rock Salt, Dry	80 - 90
Salt Sand Mix, Dry *	95 - 120

* A 1:1 ratio recommended for salt/sand mix to prevent material from freezing.

Calculate total material weight by multiplying pounds per cubic foot by cubic foot of material.

Always examine spreader for worn or damaged components prior to operation. During operation, listen for unusual noise from spreader that might indicate component failure. Never run a machine in need of repair.

Verify cover rubber latches are secure and safety cable hardware is tight before operating and driving of motor vehicle.

Start spreader for a short period of time before loading material to test for proper function of moving parts.

After loading, run spreader in an isolated area, clear of people, to become familiar with controls and to verify correct spread pattern.

Do not load material the night before or material may take in moisture and solidify before operation. Load material right before use to avoid material solidifying.

If material bridges or solidifies remove all material from hopper.

Do not leave unused material in hopper overnight. Remove all material from hopper after each day's use.

SANDER CONTROL BOX

Hiniker controllers are equipped with variable material feed, blast control, and a push button for an optional vibrator. The variable speed knob is clearly marked with full counterclockwise (CCW) being minimum speed/power and full clockwise (CW) being maximum speed/power.

6 Operating Procedures

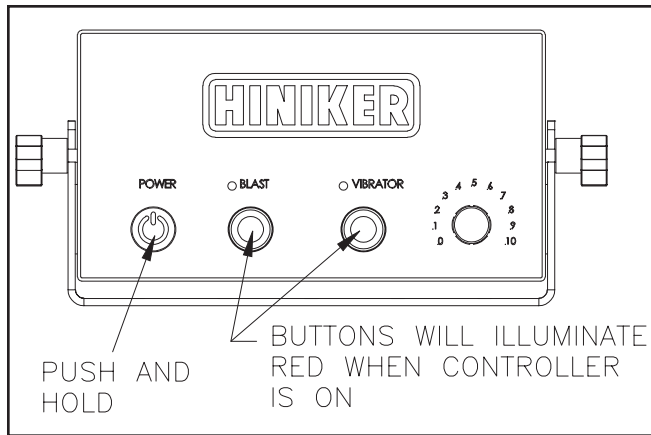

To turn on controller, push and hold power button until push button illuminates red in color.

The Hiniker controller will pulse the drive motor on and off a few times then drive motor at full power for a short duration to loosen material in hopper. The motor will then go to operator's preset speed. The speed will be shown by which numbers are illuminated red on the dial.

Example: If numbers up to 5 are red in color, spreader is set for speed setting 5.

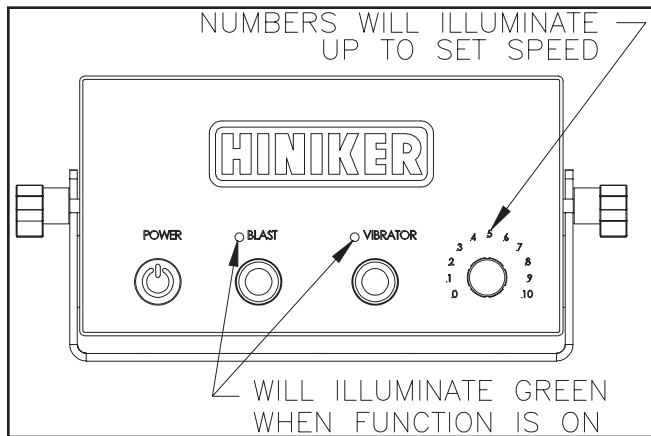

An optional vibrator is available which helps keep a steady flow of material onto spinner. It also slightly increases rate at which material is applied because a vibrator helps to put maximum amount of material onto conveying mechanism.

To activate vibrator, push vibrator button until light beside "Vibrator" button is illuminated green in color.

Important: Vibrator should be used only when necessary. Excessive use of vibrator may damage hopper. Vibrator is recommended to only be used when hopper is about 1/2 to 1/3 full until empty. Vibrator is also necessary when material is damp. Vibrator should be turned on for short durations of time to help with material flow but is not recommended to be ran continuously at any time.

Blast feature is used for slippery spots that need excess salt/sand. When blast button is held down material feed drive system runs at full power applying maximum amount of material. Light beside "Blast" button will illuminate green when blast feature is active. Once button is released blast feature will stop, and normal preset application will resume.

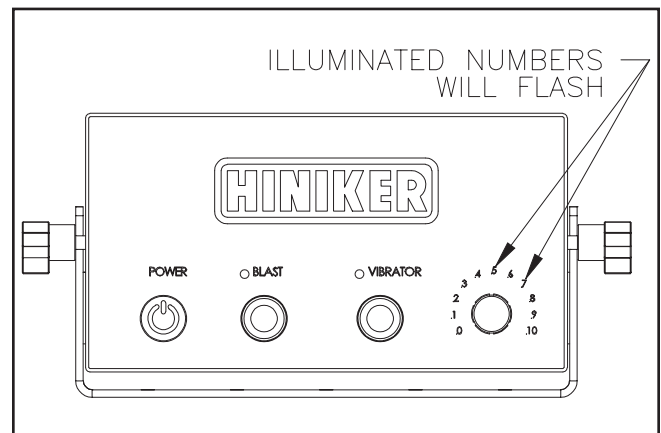

Hiniker has safety features built into the controller to protect its electrical components and motors. When a potentially damaging overload occurs the controller variable speed knob will flash red. The controller will then reduce the amount of voltage allowed to the motor and pulse the motor for 1 minute.

This is an attempt to loosen frozen, wet, or clumping material. If the motor is still drawing too many amps after 1 minute the controller will then stop sending power to motor and controller will continue to flash red.

When this happens the spreader is most likely jammed with frozen, wet, or clumping material. The operator will need to get out of truck to investigate cause of jam.

Before checking hopper be sure controller is turned off and vehicle is off and in park with ignition key in operator's pocket.

Hiniker spreaders are equipped with a bottom hopper slide gate to make checking material jams easier. This gate is also used to empty material out of hopper after each days use or to empty hopper if frozen, wet, or solidified material is in hopper.

To open bottom slide gates first loosen wing nut on both slide gates. Pull on outer formed edge of both gates simultaneously to open. Remove blockage and then slide gates until they are almost touching auger tube and retighten wing nuts. Dry material may now be put into hopper. Controller will need to be shut off and back on to resume material spreading.

SPREAD CONTROL

Spread pattern is controlled by (2) variables motor speed and vehicle speed. The drive and spinner motor are coupled together making them run at the same RPM. As the drive motor is sped up the material feed rate is increased. This also increases the speed of the spinner making a wider less populated spread pattern. If the motor is ran at a slower speed the feed rate decreases. This will decrease the spinner speed and cause a smaller but heavier populated spread pattern.

The other variable is vehicle speed, a slower vehicle speed results in heavier populated spread pattern.

TRANSPORTING SPREADER

When transporting Hiniker spreaders it is essential that the spreader is tied down using ratcheting tie down straps to the rear corners of the spreader (as shown).

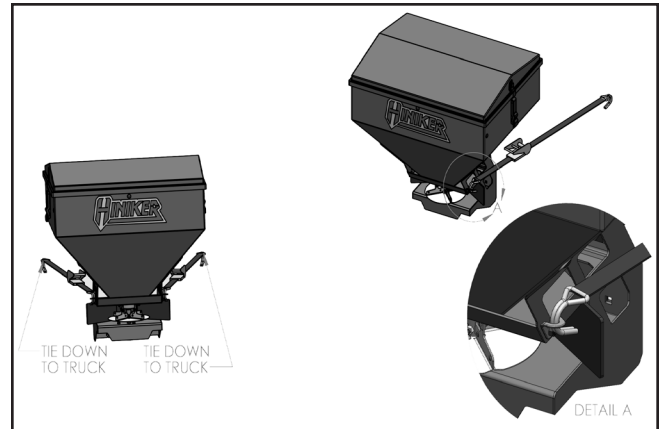

It is recommended to attach tie downs so they are pulling at a frontward and upward angle. This will help take some of the weight off the receiver hitch as well as stabilizing the spreader. It is recommended to attach the ratchet straps to the tie downs in the bed of the truck.



WARNING: Verify cover is secure to hopper before transporting vehicle or death, injury, or vehicle damage could occur.

It is important to verify cover is secured to hopper using rubber latches before transporting spreader or a potentially dangerous situation may occur. Also verify safety cable hardware is tight and cables are in good working condition.

SWING AWAY KIT (Optional)

Hiniker Swing Away Kit makes loading of pallets of bagged material into the back of a vehicle easier. The swing away option can only be used when the hopper is completely empty.

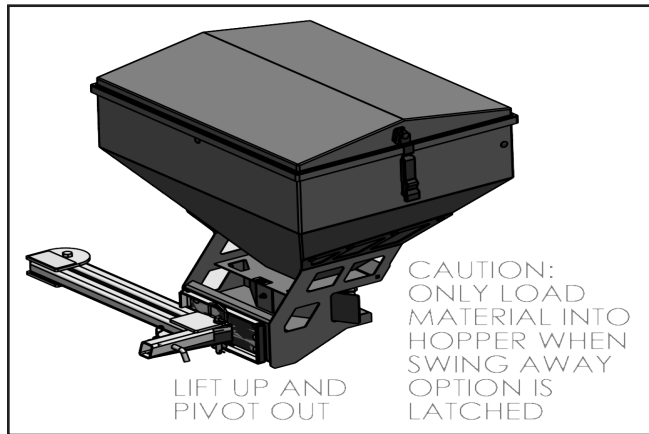

For loading material into back of vehicle remove pin. Lift up on rear of spreader hopper frame while pulling out or away from vehicle to unhitch hopper from swing away frame. Swing hopper out of bed area to allow material to be loaded into rear of vehicle.

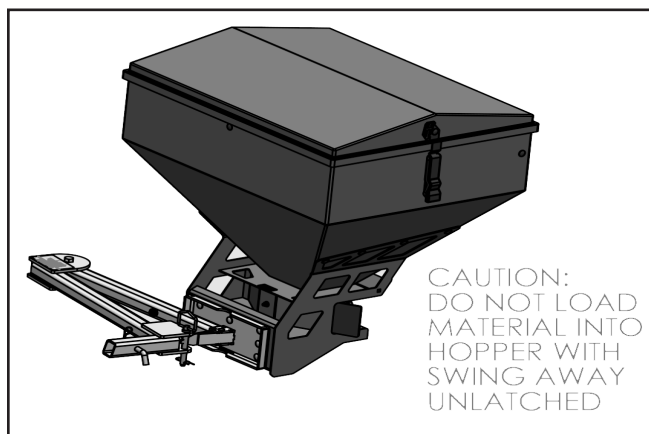

To relock hopper in place, swing hopper until prong touches receiver tube. Lift up on back of spreader hopper frame and push prong into receiver tube. Push hopper in until hitch pin can be inserted locking hopper to receiver frame. Insert hitch pin and secure with hairpin.

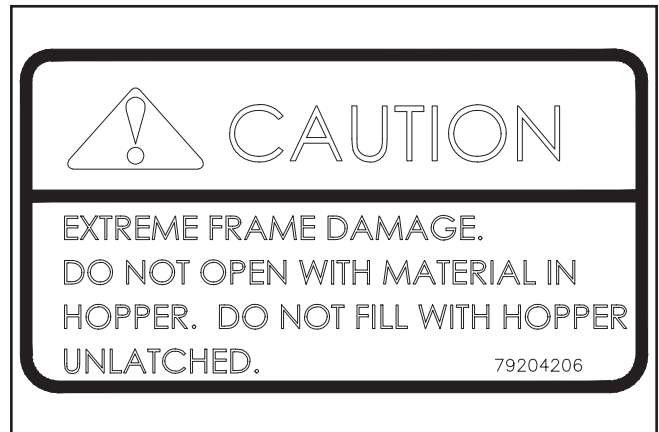

DWG NO. 7272

VIBRATOR KIT (Optional)

Hiniker vibrator kit is to eliminate bridging and assure continuous flow of dry material to the auger.

Important: Vibrator should be used only when necessary. Excessive use of vibrator may damage hopper. Vibrator is recommended to only be used when hopper is about 1/2 to 1/3 full until empty. Vibrator is also necessary when material is damp. Vibrator should be turned on for short durations of time to help with material flow but is not recommended to be ran continuously at any time.

STORAGE

Store spreader in a cool dry protected area when it will not be used for an extended period of time. Never attempt to remove spreader with material in hopper. Perform these maintenance procedures at end of season to ensure machine remains in good operating condition:

1. Unload hopper completely and wash to flush out any remaining material to prevent material buildup. Do not pressure wash motor or electrical components or damage will occur.
2. Disconnect and remove controller from spreader. Store in a cool dry place. Summer temperatures and climate could damage circuit boards and void warranty.
3. Apply a light coat of dielectric grease to all electrical terminals, and cap or tape loose terminals to prevent damage or corrosion.
4. Inspect for worn or damaged components. Repair or replace as needed.

MAINTENANCE & SERVICE PROCEDURES

Dependable spreader operation is a result of following good maintenance procedures. Inspect your spreader frequently to ensure that all parts are working smoothly, and develop a schedule for maintenance at required intervals.

GENERAL







Always disconnect power from wiring harness before servicing or replacing any electrical components. Prior to operation of a new spreader, or one that has been stored, inspect all hardware and verify proper torque on all bolts and nuts in accordance with recommended torque specifications.

Apply a light coat of dielectric grease to all electrical connectors to prevent corrosion of contacts when connectors are unplugged, and to make connecting and disconnecting plugs easier.

Remove all material from hopper and wash salt and dirt off spreader before storage. Do not pressure wash motor or electrical components as damage may occur.

Never leave material in hopper overnight. Material may freeze or solidify and seriously damage spreader or components.

Controller is not serviceable. If controller does not function a new one must be purchased.

STANDARD MARKINGS AND TORQUE SPECIFICATIONS			
Manufacturer marks may vary. These are all SAE Grade 5 (3 - line).			
			
SAE Grade Number	1 or 2	5	8
Capscrew Head Markings			

DWG. NO. 1935

TABLE 1 RECOMMENDED TORQUE VALUES FOR INCH FASTENERS (ZINC COATING & LUBRICATED)**				
Nominal Size	SAE 5 120,000 psi Min Tensile Str lbf - ft		SAE 8 150,000 psi Min Tensile Str lbf - ft	
	Dry	Lubricated	Dry	Lubricated
1/4-20	8	6	12	9
5/16-18	17	13	25	18
3/8-16	30	23	45	35
1/2-13	75	55	110	80
5/8-11	150	110	220	170

** MACHINE DESIGN FASTENER AND JOINT REFERENCE ISSUE

Loose bolts can cause hole elongation and part failure resulting in dangerous operating conditions and equipment breakdown.

Check all hardware periodically during operation and keep tightened to specified torques. Replace worn bolts and locknuts, as needed.

TROUBLE SHOOTING

Preliminary Checks:

- Be sure all electrical connections are tight and clean.
- Be sure nothing is jammed in hopper or spinner.

PROBLEM	POSSIBLE CAUSE	REMEDY
No power to cab Power switched to ON position No illumination of indicator light	Controller plug is loose	Check plug connection at cab control
	Blown fuse	Replace fuse
	Faulty battery	Check battery voltage should be between 13 - 15 Volts with vehicle running
	Vehicle wiring harness damaged between battery and controller	Repair/Replace damaged wires or harness as required.
Control Dial does not change speed Controller does not function	Malfunctioning cab control	Replace controller
	Wiring harness is damaged or has a short between cab control and spreader	Check plug connections at cab controller and spreader motors
Material feed motor does not operate Controller display blinks red	Material feed jam	Remove obstruction
	Frozen material Solidified or clumping material	Thaw material Replace material
	Slide gates too tight on auger shaft	Increase clearance between slide gates and auger shaft
	Material jammed between slide gates and auger tube	Remove jammed material
Motor doesn't run	Loose electrical connections	Check/tighten all connections
	Jammed material feed/spinner	Remove obstruction
	Motor seized	Replace motor
Material not flowing from hopper	Wet or Frozen material	Replace with Dry material
	Material feed jammed	Remove obstruction
	Material bridge	Remove bridge

INSTALLATION INSTRUCTIONS

STANDARD MARKINGS AND TORQUE SPECIFICATIONS			
Manufacturer marks may vary. These are all SAE Grade 5 (3 - line).			
SAE Grade Number	1 or 2	5	8
Capscrew Head Markings			

DWG. NO. 1935

TABLE 1 RECOMMENDED TORQUE VALUES FOR INCH FASTENERS (ZINC COATING & LUBRICATED)**				
Nominal Size	SAE 5 120,000 psi Min Tensile Str lbf - ft		SAE 8 150,000 psi Min Tensile Str lbf - ft	
	Dry	Lubricated	Dry	Lubricated
1/4-20	8	6	12	9
5/16-18	17	13	25	18
3/8-16	30	23	45	35
1/2-13	75	55	110	80
5/8-11	150	110	220	170

** MACHINE DESIGN FASTENER AND JOINT REFERENCE ISSUE

MOUNTING SPREADER

1. Remove spreader from shipping container.
2. Remove zip tie securing grid to hopper. Carefully remove grid from hopper to access parts box.
3. Remove Hiniker controller, wiring harness, ratchet straps, etc from parts box.

Verify everything has been removed from inside the hopper.

4. Reassemble hopper grid and hopper cover onto hopper assembly. Securely fasten rubber latches.

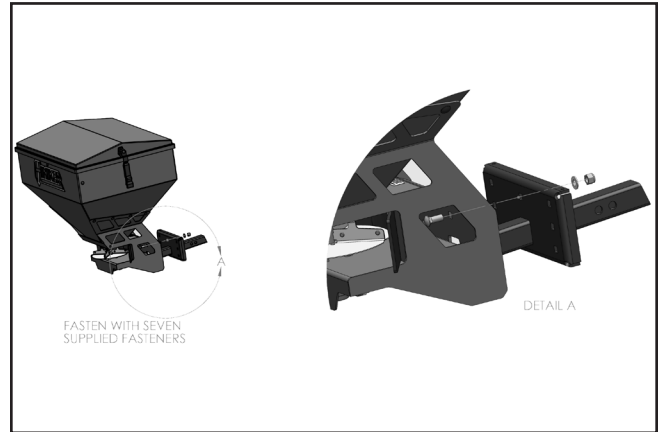

5. Assemble 2" receiver assembly onto front side of hopper assembly using provided 1/2" hardware, if not already assembled.

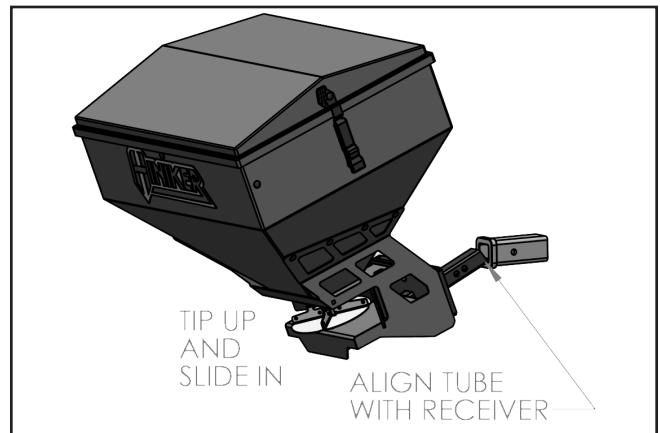

6. With hopper near 2" receiver on vehicle. Tip spreader back and align bottom edge of 2" spreader tube with vehicle 2" receiver. Slide 2" tube partially in and lift up while pushing in to fully mount spreader in vehicle.
7. Secure spreader in place using provided 5/8" hitch pin and hairpin.

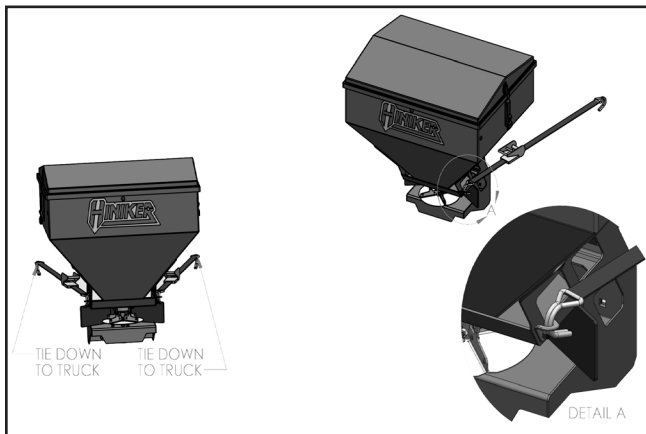

- Use ratcheting tie down straps to secure hopper to truck bed built in tie downs.

CONTROL BOX AND VEHICLE WIRING INSTALLATION

Locate wiring harness removed from inside hopper assembly.

To insure good performance of your spreader, check condition of trucks electrical system. Using a voltmeter, check alternator and battery voltage. With engine running and headlights and heater fan on, a good voltage reading should fall between 13.0 and 15.3 volts. If reading falls out of this range, check and adjust your electrical system.

Refer to drawing 7295 on following page. Lay out a wiring path for spreader wiring harness. Connect wiring harness connectors to their mating connectors on drive motor and vibrator (if equipped). Drill all necessary holes or use existing ones to pass connectors into truck cab. Attach harness to truck frame. Do not route wiring harness near exhaust system, or harness may melt and short electrical system.

Mount controller in a convenient location in truck cab. Do not mount controller directly in front of heater vents, as this will raise temperature of controller significantly and may cause damage to your spreader controller.

CAUTION: Do not install controller in deployment path of an air bag. Refer to vehicle manufacturer's manual for air bag deployment areas.



Attach mating connectors between wiring harness and cab controller.



CAUTION: Make sure power switch on controller is off before connecting power cable.

Lay out a path for power cable in truck's engine compartment. Drill a hole in firewall or use an existing one to pass wiring harness. It is recommended to pass power cable from inside of cab to battery due to a large high amperage connector. Do not route close to engine or exhaust system, or harness may melt and short electrical system.

Refer to drawing 7295 on following page. Connect black lead to battery ground (-) terminal. White is attached to positive (+) post of battery.

Connect power cable to controller.

Push on/off button on controller to check for power. When power has been confirmed turn power off. Electrical installation now is complete. Refer to "Operating Procedures Section" for more information on controller function.

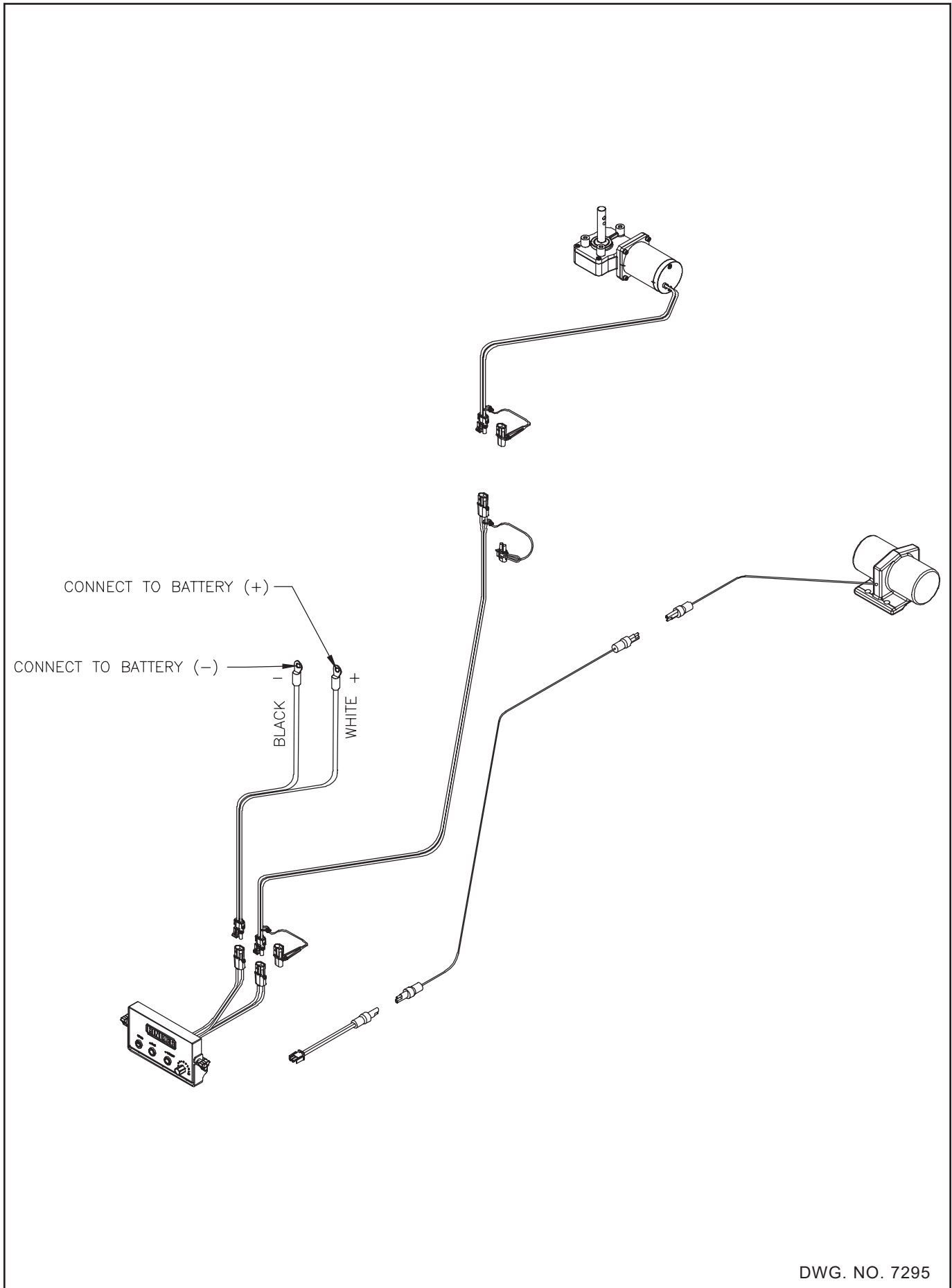

SPECIFICATIONS

DIMENSIONS:	600P HOPPER	1000P HOPPER
Overall Length	25 Inches	29 1/2 Inches
Overall Width	32 Inches	38 1/4 Inches
Overall Height	36 1/2Inches	39 Inches
Hopper Length	24 Inches	28 Inches
Hopper Width	30 Inches	35 1/2 Inches
CAPACITY: Cubic Foot		
Level	6	10
Weight: Model Hopper Only	120 lbs.	136 lbs.
AUGER:		
Auger Diameter:	6 Inches	6 Inches
Electric Drive		
Drive Motor	1/3 HP 12 V DC Electric Motor	
Spinner Diameter:	10 Inches	10 Inches
Shaft Diameter:	3/4 Inch	3/4 Inch
Spreader Pattern	Up To 25 Feet	Up To 25 Feet

HINIKER WARRANTY

HINIKER SPREADER LIMITED WARRANTY

The only warranty Hiniker Company (Hiniker) gives and the only warranty that any Hiniker dealer is authorized to give on behalf of Hiniker is as follows: **(NO EMPLOYEE OR REPRESENTATIVE IS AUTHORIZED TO CHANGE THIS WARRANTY IN ANY WAY OR GRANT ANY OTHER WARRANTY.)**

Hiniker warrants to the original purchaser of a Hiniker spreader that Hiniker will repair or replace any defects in material and workmanship that occur within two years from date of retail delivery except the following items: Hiniker warrants that it will repair or replace any defects in materials or workmanship with respect to the paint finish, any accessories, and service parts and components for a period of one year from date of retail delivery.

Hiniker's obligation and liability under this warranty is expressly limited to repairing or replacing, at Hiniker's option, at an authorized Hiniker dealer location, the defective parts at no charge to the original purchaser. **HINIKER MAKES NO OTHER WARRANTY, EXPRESS OR IMPLIED AND MAKES NO WARRANTY OF MERCHANTABILITY OR OF FITNESS FOR ANY PARTICULAR PURPOSE.**

HINIKER'S OBLIGATION UNDER THIS WARRANTY SHALL NOT INCLUDE ANY TRANSPORTATION CHARGES TO OR FROM THE AUTHORIZED HINIKER DEALER LOCATION OR ANY LIABILITY FOR INCIDENTAL, INDIRECT OR CONSEQUENTIAL DAMAGE OR DAMAGES OF ANY KIND FOR LOST PROFITS OR DELAY. If requested by Hiniker, products or parts for which a warranty claim is made are to be returned freight prepaid to our factory. Any improper use, operation beyond rated capacity, substitution of parts not approved by Hiniker Company, or any alteration or repair in such manner as in our judgment affects the product materially and adversely shall void this warranty.

Hiniker reserves the right to make improvements or changes to any of its products without notice. Such improvements or changes shall not trigger any obligation by Hiniker to update, modify or change any products previously sold by Hiniker.

HINIKER does not warrant the following:

1. Used products.
2. Any product that has been repaired, modified or altered in a way not approved by Hiniker Company.
3. Depreciation or damage caused by normal wear, lack of reasonable and proper maintenance, failure to follow Operators Manual Instructions, misuse, lack of proper protection during storage, or accident.
4. Parts replacement and service necessitated by normal wear or maintenance including, but not limited to, auger flighting, electric motor, and spinner disc.
5. Paint finish damage caused by normal wear.

Hiniker does not assume any liability for any damage to a motor vehicle resulting from the attachment or use of a Hiniker spreader. Compliance with applicable motor vehicle regulations is the responsibility of the installer. Attachment of a Hiniker spreader to a motor vehicle is at the risk of the purchaser.

It is the responsibility of the original spreader purchaser to verify the original date of purchase.

Dealer must submit PRODUCT REGISTRATION and fill out a DELIVERY REPORT FORM online within 30 days of retail delivery to initiate the warranty coverage.

HINIKER COMPANY
58766 240th Street
Mankato, MN 56001
PHONE 800-433-5620 -- FAX (507) 625-5883
<https://snowplows.hiniker.com/>