



PICKUP TRUCK SNOWPLOW STEEL STRAIGHT PLOW

Models 2754, 2804, 2854

ASSEMBLY INSTRUCTIONS

**DO NOT USE OR OPERATE THIS EQUIPMENT UNTIL THIS MANUAL
HAS BEEN READ AND THOROUGHLY UNDERSTOOD**

Please visit www.snowplows.hiniker.com to access the most recent version

PART NUMBER 25014882

TABLE OF CONTENTS

25014882

8/2023

Hiniker/25014882

GENERAL PLOW ASSEMBLY	2
FRAME TO MOLDBOARD ASSEMBLY	3
HYDRAULICS ASSEMBLY	4
PLOW ELECTRONICS ASSEMBLY	5
TRUCK ELECTRONICS & MOUNT KIT ASSEMBLY	7
SYSTEM CHECKOUT	10
CONTROLLER CONFIGURATION	12
HEADLAMP AIMING PROCEDURE	13
WARRANTY	14

GENERAL PLOW ASSEMBLY

WARNING: To prevent personal injury or death, be certain to keep clear of any parts that may drop when removing bundling straps, wires or brackets. Support heavy sections with hoist or blocks before removing wires or straps.



In the following instructions, left and right machine references are defined as being viewed from the cab of the truck.

Be certain that hydraulic hoses and electrical wires are safely routed and allow full motion of moving parts. Secure loose wires with plastic tie straps.

Some components are fastened at incorrect locations for shipping purposes.

All hardware should be tightened only enough to ensure safety during assembly. Torque hardware to specified values, as shown in the following chart, only after assembly has been completed.

GRADE 5 TYPE B & F LOCK NUT TORQUE VALUES

Size	Ft-lbs.	N-m
5/16"	13-18	17-25
3/8"	23-33	31-44
1/2"	58-82	79-112
5/8"	117-165	158-223

GRADE 5 BOLT TORQUE VALUES*

Size	Ft-lbs.	N-m
1/4"	8-12	11-16
3/8"	29-41	39-56
1/2"	73-103	99-140
5/8"	146-206	198-279

* applications without lock nuts

Replace worn bolts and lock nuts with grade 5 bolts and equivalent type B and type F lock nuts. Type B lock nuts are plain hex; type F lock nuts are flanged hex.

WARNING: Snow plow has O-ring hydraulic fittings on the pump, hoses and hydraulic cylinders. DO NOT use pipe sealant or over tighten during assembly.



After assembly validate all hydraulic connections are tight. Factory installed connections may loosen during shipping.

NOTE: New hydraulic cylinders will leak a small amount of oil until packings become saturated and produce a good seal. If leakage is excessive, or if leaking continues after initial cycling, tighten the packing nut in 1/8 turn increments until leaking stops.

NOTE: Discard any lock nuts removed while transitioning the plow from shipping configuration to final configuration. Utilize new lock nuts provided in Op manual bag.

FRAME TO MOLDBOARD ASSEMBLY

1. Place moldboard face down on cardboard or other padding that will prevent scratches in the paint.

Remove two side markers and four shipping straps from the ends of the moldboard.

NOTE: Additional compression springs are included with 8 1/2' moldboards. Remove springs and set aside for reassembly.

2. Open the frame box and set aside the hardware bag, power unit box and electronics box for later assembly. Remove the frame assembly from the shipping box to a piece of cardboard or other padding that will prevent scratches in the paint.

Carefully lift the frame assembly by wrapping straps or padded chains around both ends of the 2 1/2" square tube at the rear of the frame. Attach the frame assembly to the moldboard by lining up the three bushings on the frame with the three sets of bushings on the moldboard.

Apply commercially available anti-seize lubricant (not supplied) to the hinge pins to prevent future corrosion, and reinstall the hinge pins through the bushings. Secure the hinge pins with spring pins.

Remove 3/4" lock nuts from the back of each compression spring and discard. Align each pullrod bushing with the upper set of holes in the moldboard ribs and reinstall 5/8" bolts and lock nuts. Tighten lock nuts only until snug against ribs.

Assemble new 3/4" lock nuts back onto pullrods and tighten until compression springs measure 13" long. Do not overtighten springs.

NOTE: If assembling an 8 1/2' plow, remove endcaps from compression springs and install an extra spring inside each existing spring. Place endcaps on springs and tighten 3/4" lock nuts on pullrods until the outer springs measure 13" long. Do not overtighten springs.

3. Gently tip the plow assembly to its working position with a hoist or forklift. Pin the parking stand to hold the square tubes of the push frame parallel to the ground.

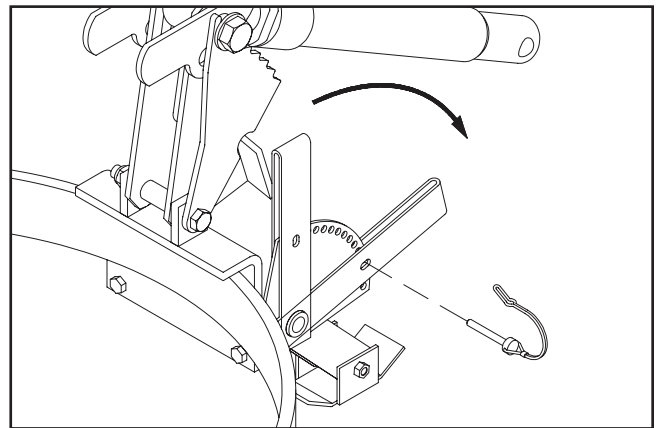

DWG NO. 4201A

NOTE: The bottom surface inside the two prong receiver channels should measure about 10" above the ground in the working position.

HYDRAULIC ASSEMBLY

1. For Halogen lights Only: Before assembling the power unit on the lift frame, scrape a small amount of paint from the two mount holes in the lift frame to provide a good electrical ground for the turn signals and parking lights.
2. Mount the power unit on the lift frame with two 3/8" x 3/4" hex bolts and two 3/8" lock washers. The plastic reservoir of the power unit should be to the left side of the plow, see following illustration.

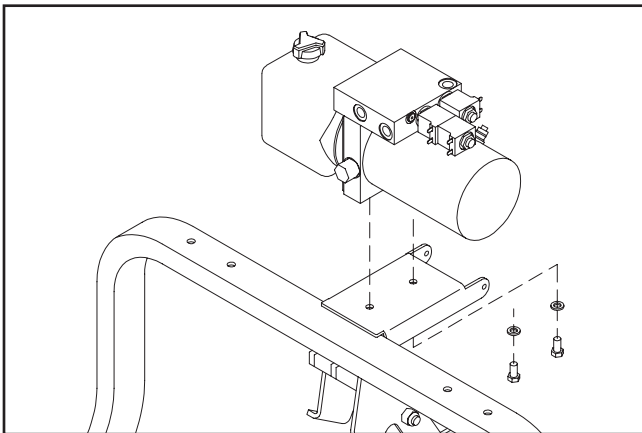

DWG NO. 6595A

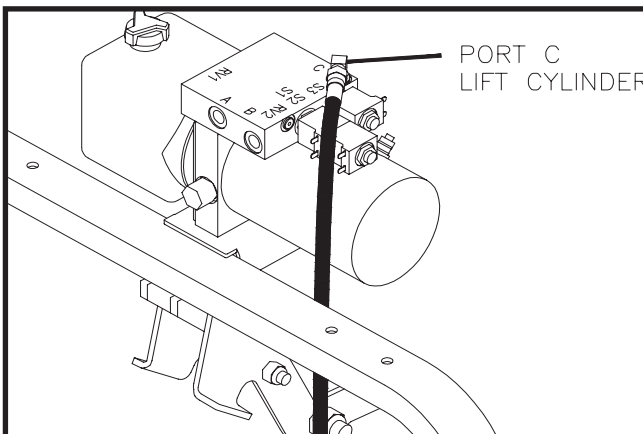

DWG. NO. 6484A

3. Install the adapters into power unit, then fasten the hoses to the adapters matching the letter ends to the letters on the manifold.

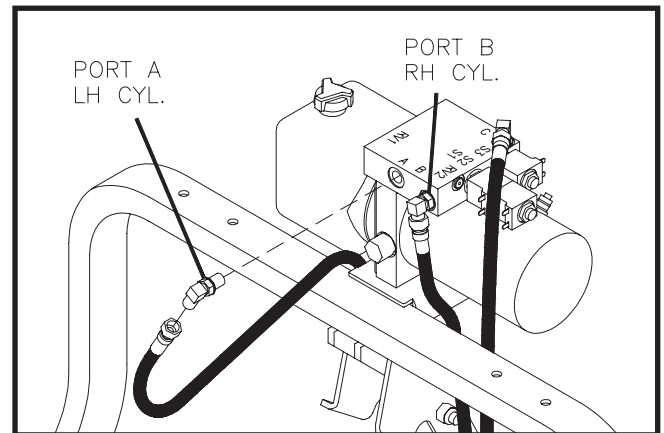

DWG NO. 6485A

4. Ensure factory installed fittings are tight. Then secure hoses ensuring they clear the lift links and latch handle.

NOTE: The fitting in the LH side angling cylinder may have to be adjusted slightly to route the hydraulic hose to best avoid interference with the latch handle and the lift links. Use plastic tie straps to secure all hydraulic hoses away from lift link stops.

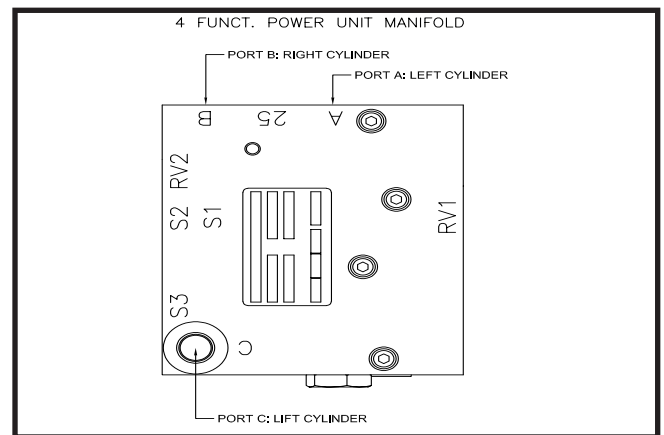

DWG NO. 4fct Manifold

PLOW ELECTRONICS ASSEMBLY

NOTE: Check 1/4" bolts provided in LED headlight box. If they do not have a pre applied Loc-tite patch, apply anti-sieze to the bolts to prevent galling.

NOTE: Do not use an impact driver, tighten bolts by hand to prevent galling and damage to headlight housing.

1. Mount the headlamp brackets to the lift frame tube with hardware provided in light parts box.

Remove the LH and RH headlamps from their box and mount on the brackets with the provided hardware.

Refer to section titled "Headlamp Aiming Procedure" for aiming instructions.

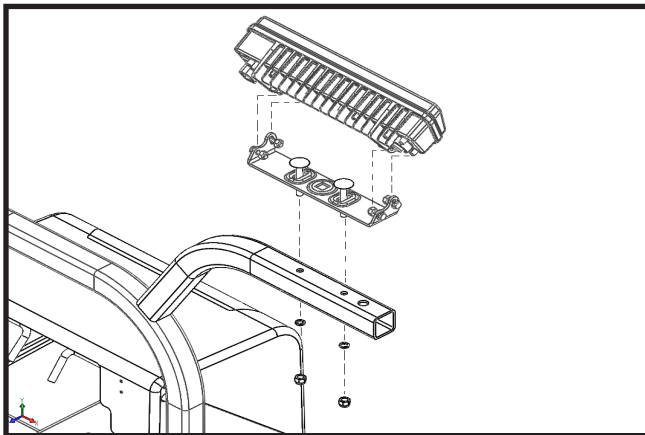

DWG. NO. 6012F

2. Take the 38" power cable (38812008) from the electronics parts box and the plow side harness (38813155 for LED) or (38813098 for Halogen) from the headlight parts box.

NOTE: To prevent corrosion lightly coat all electrical connections, ring and spade terminals with dielectric grease prior to assembly.

3. Fasten the ring terminal of the solid black wire of the power cable assembly to the stud that the solenoid ground cables are running to on the motor.
4. Attach the ring terminal of the red striped wire of the power cable assembly to the unoccupied terminal on the motor.
5. Connect the RH headlamp to the harness end labeled "PSNGR SIDE" and the LH headlamp to the end labeled "DRIVER SIDE".

6 Plow Electronics Assembly

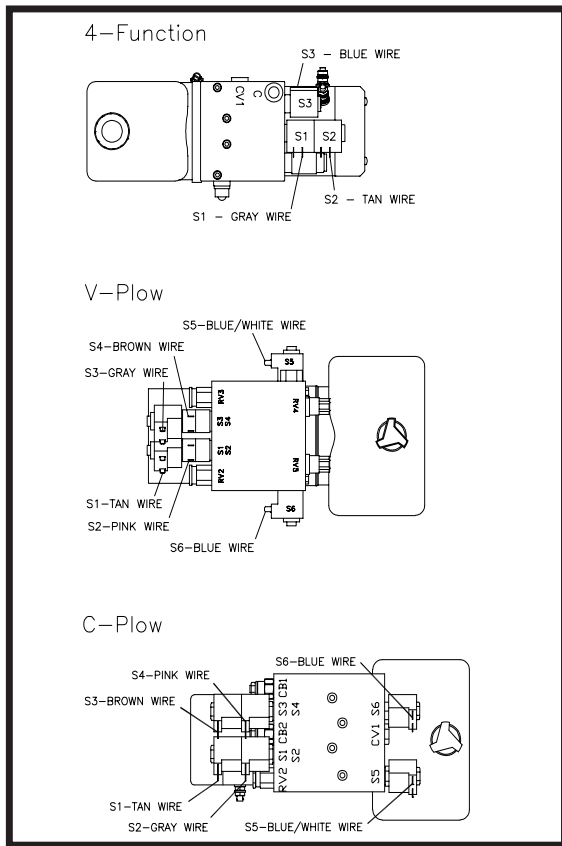

DWG. NO. 8007

NOTE: Install the plow harness so that water does not run down the wires and pool inside the "Y" connection. Position the harness so that any trapped water can easily drain away.

- Refer to drawing 6013F. Use plastic tie straps to secure plow wiring harness to lift frame tube and headlamp bracket at the locations shown by arrows 3 and 4.

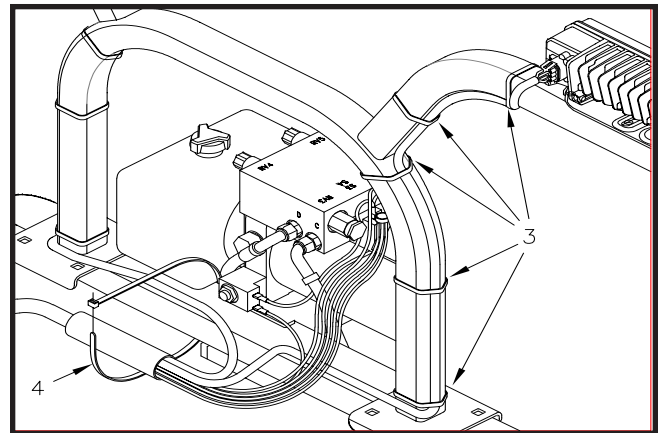

DWG. NO. 6013F

- Refer to drawing 8007 and the chart below to connect the plow wiring harness to the power unit solenoids.

Wire to Solenoid Chart

	4 Function	V-Plow	C-Plow
Tan	S2	S1	S1
Pink	not used	S2	S4
Gray	S1	S3	S2
Blue w/ White	not used	S5	S5
Blue	S3	S6	S6
Brown	not used	S4	S3

TRUCK ELECTRONICS & MOUNT KIT ASSEMBLY

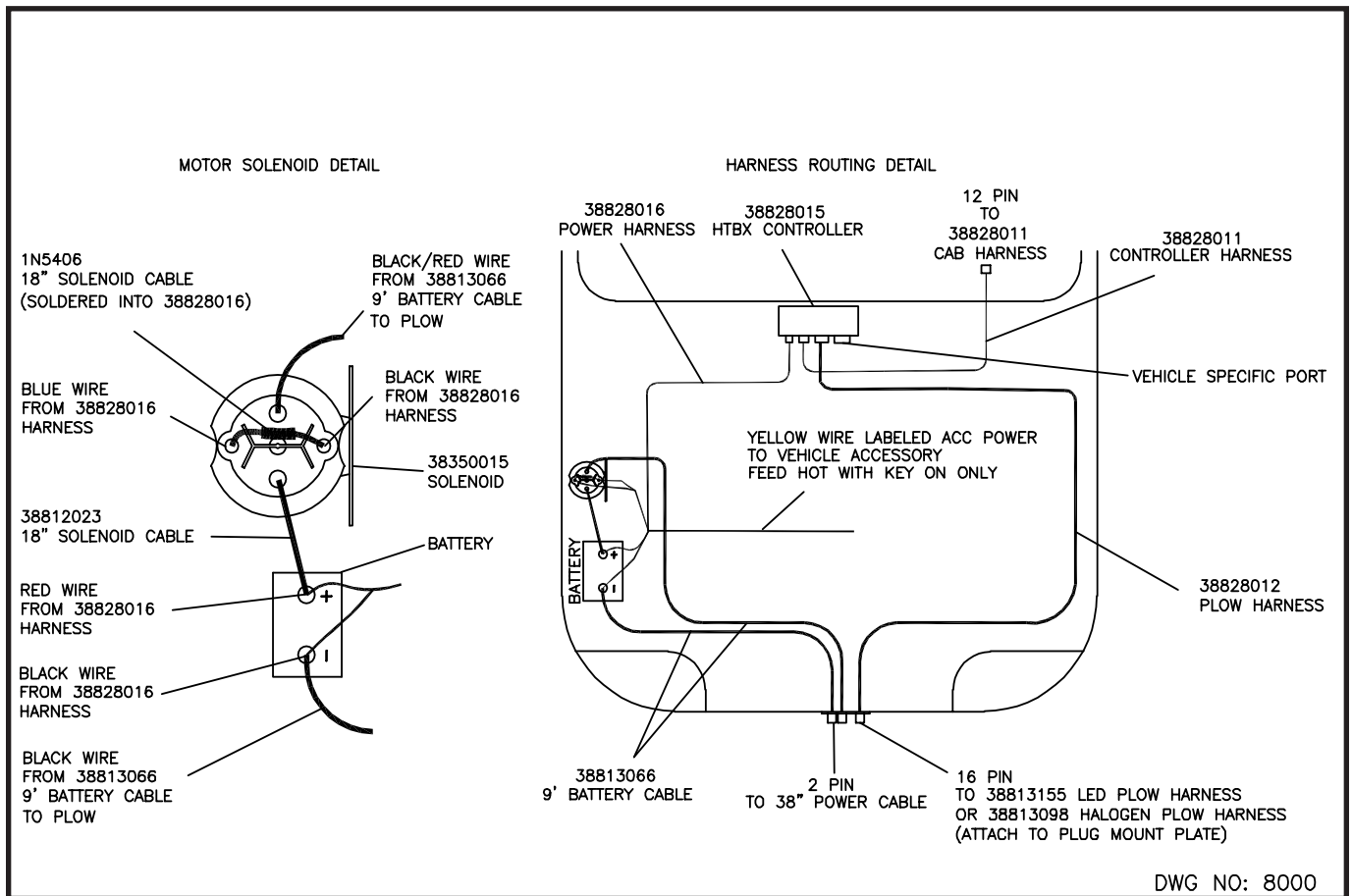

Truck Battery On Passenger Side

WARNING: Disconnect truck battery before beginning electrical installation to avoid shock hazard.

Open the electronics parts box and validate you have all components, harnesses, and hardware per the checklist inside the box.

NOTE: To prevent corrosion, apply a light coat of dielectric grease on all connectors and terminals before installation.

1. Refer to drawing 8000 & 8001 for a general guide on routing the HTBX electrical system harnesses. Not all engine compartments are compatible with the routing shown in the drawings 8000 & 8001. Installers must use their best judgement to route the harnesses ensuring everything is secured from hot or moving components.

2. If there is no access hole in the driver's side firewall then drill a 1" diameter hole. Route the 12 pin rectangular connector of the controller harness (38828011) from the HTBX controller through the firewall into the cab compartment. If required, install the 4" grommet in the hole.

CAUTION: Ensure that the electrical system will clear any hood lift/spring mechanisms before installation.



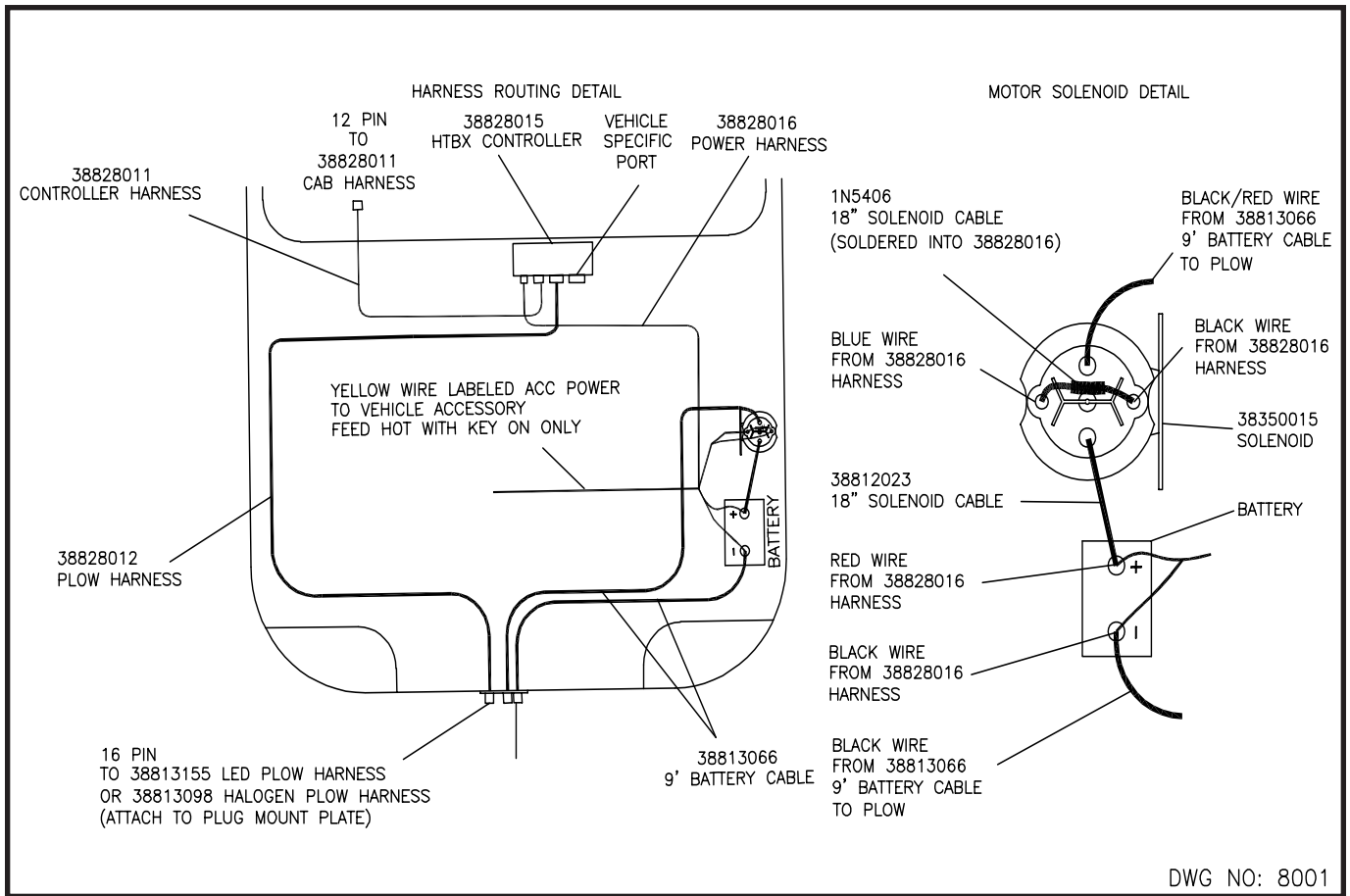

Truck Battery On Driver Side

3. Splice the yellow wire to the vehicle's 12 volt auxiliary electrical circuit. This will prevent operation of the plow without the vehicle's key being on.
4. Connect the dark blue end of the cab harness (38828030) to the controller harness (38828012) inside the truck cab. Then connect the black & white end of the cab harness to the universal controller (38828019), Refer to the controller configuration section for instruction on how to configure the controller with the correct plow setting, and the operators preferred joystick configuration. Once configured, secure the case together with the provided hardware.

CAUTION: To prevent injury or property damage caused by unintentional plow movement when the key is removed from the vehicle, the yellow wire must be connected to a switched power source on the vehicle. Connecting to a power source not controlled by the ignition switch will allow movement of the plow with the vehicle key removed.

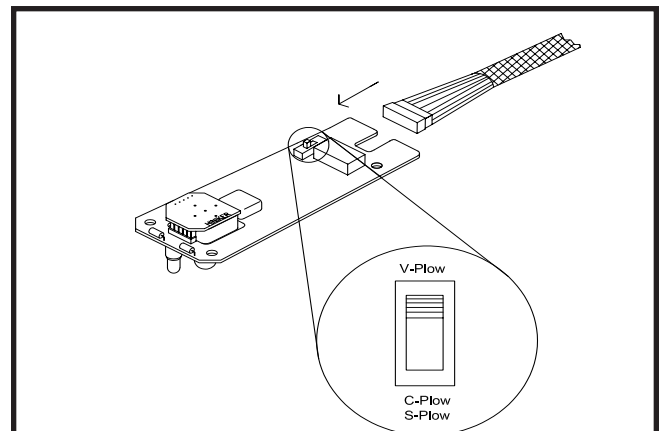

DWG. NO. 8006

CAUTION: Ensure that the electrical system will clear any hood lift/spring mechanisms before installation.



NOTE: Do not over tighten nuts on the motor solenoid terminals. Over-tightening causes premature solenoid failure. Refer to torque specifications on the solenoid.

5. Select an area within 16" of the vehicle battery for the motor solenoid placement. Using the solenoid bracket as a template, mark and drill two 3/16" diameter holes then fasten the solenoid with two 1/4" x 1/2" long self tapping screws provided in the electrical parts box.
6. Safely route the 16 pin plow harness (38828012) from the HTBX controller through the grill of the vehicle to a location that will be easily accessible with the plow attached.
7. Refer to drawings 8000 or 8001 for connecting the power cable and harness:
 - a. Connect the black terminal from the 9' battery cable (38813066) and the black wire from the power harness (38828016) to the minus(-) post of the vehicle's battery or the vehicle's designated ground stud.
 - b. Connect the red striped terminal from the 9' battery cable (38813066) to the motor solenoid then route the battery cable through the grill near the 16 pin plow connector.
 - c. Connect the 24" red cable to the motor solenoid.
 - d. Connect the red fused wire from the power harness (3882016) and the free end of the 24" red cable to the plus(+) terminal of the battery or battery access post.
 - e. Connect the black wire & the blue wire from the power harness (38828016) to the small posts of the motor solenoid, polarity is not important.

8. See instruction sheet provided with vehicle specific harness for hooking up the HTBX system to the vehicle's headlights.
9. To complete the electrical installation: connect all harnesses to the HTBX controller and secure all harnesses & cables away from hot or moving components with the provided cable ties.
10. See instruction sheet provided with the vehicle specific mount kit to finalize the vehicle part of the plow installation.

NOTE: Prongs from the mount kit should be at a height that will slightly lift the plow frame when attaching the plow. General rule of thumb is 9" from the ground to the underside of the prong. This can vary if the truck has a modified suspension.

NOTE: Powdered graphite can be used on the prongs to help the plow slide on and off more easily.

NOTE: Prong receivers on the plow frame must be parallel to the ground before attaching the plow. Always follow the attaching and detaching instructions that are decal'd on the rear side of the plow blade.

SYSTEM CHECKOUT

1. Prongs from the truck mount kit should be at a height that will slightly lift the plow frame when attaching the plow. Prong receivers on the plow frame should be parallel to the ground when attaching the plow. Apply powered graphite on the truck prongs to help the plow to slide on and off more easily.

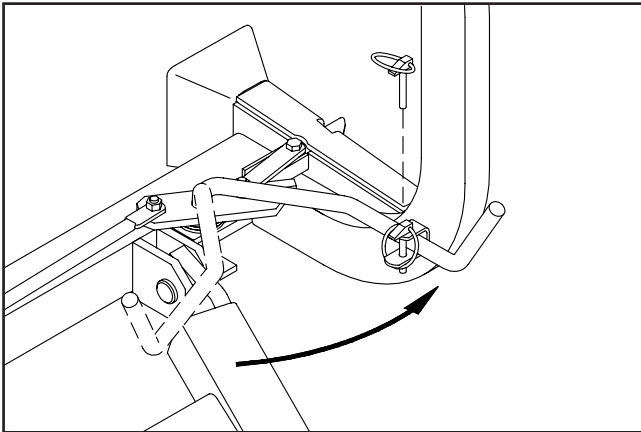

Handle Pinned With Plow on Truck DWG NO. 4199

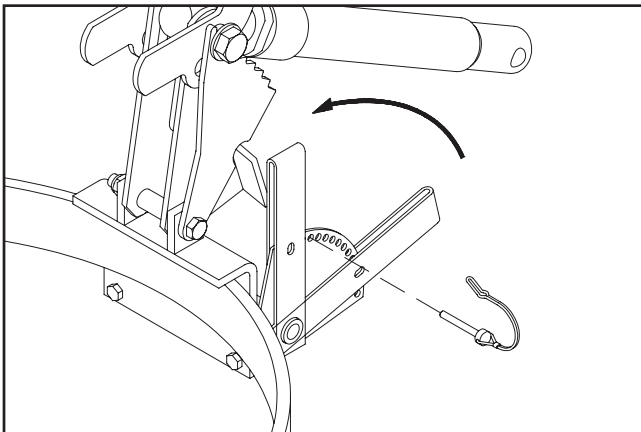

DWG NO. 5286A

2. Connect the electrical cables from the plow to their corresponding receptacles on the truck. Validate the power connection is red stripe to red stripe and black to black.

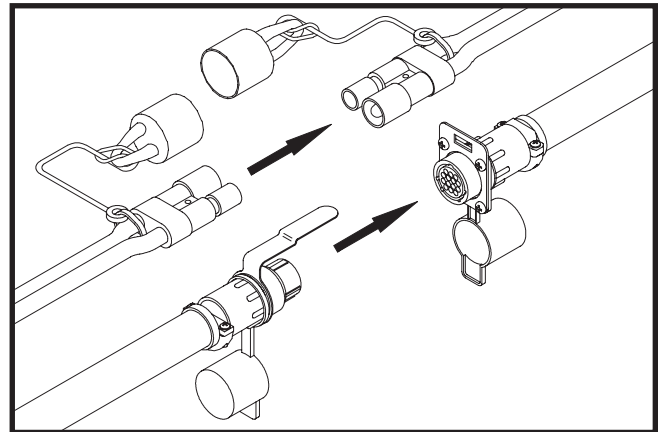

DWG. NO. 6697

3. Select Hiniker Cold Flow Hydraulic Oil or an equivalent oil that meets military specification 5606, for plowing in extremely cold temperatures.

Pour hydraulic oil into the power unit oil reservoir until the reservoir is half full.

Angle the plow full left or right with the cab control box inside the truck to fill the angling cylinder with oil. Add more oil until the reservoir is about 3/4 full. Do not over-fill the reservoir.

Cycle the plow left and right and up and down to purge any air trapped in the hydraulic system.

Check the oil level with the plow on the ground. Add oil to the fill line, if necessary, but do not over fill the reservoir.

NOTE: New hydraulic cylinders will leak a small amount of oil until packings become saturated and produce a good seal. If leakage is excessive, or if leaking continues after initial cycling, tighten the cylinder packing nut in 1/8-turn increments until leaking stops.

- Fasten the power unit cover assembly to the lift frame bracket with two 1/4" x 3/4" screws, flat washers and lock nuts from the hardware bag in the power unit box. Tighten the lock nuts so that the assembly is secure, yet the cover hinges freely.

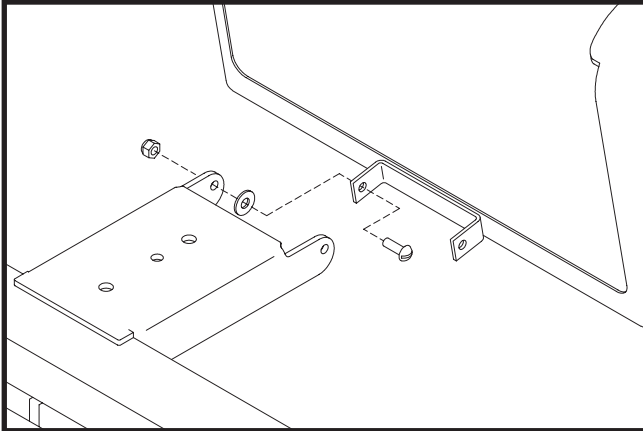

DWG. NO. 6310

NOTE: When the cover is closed, rods from the latch handles should extend behind the light brackets to hold the cover in place.

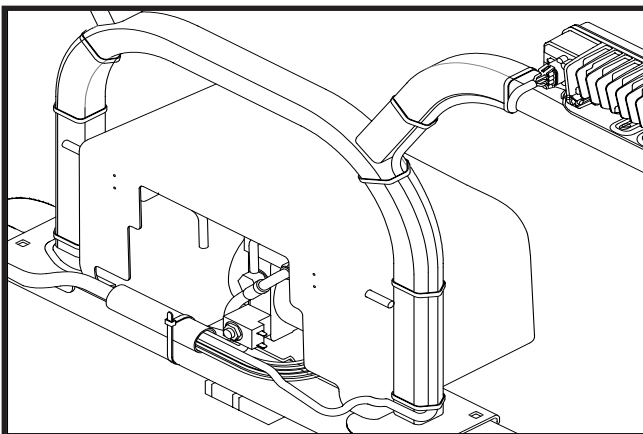

DWG. NO. 6014D

- Assemble side markers on the ends of the moldboard with 5/16" bolts, flat washers and lock nuts.

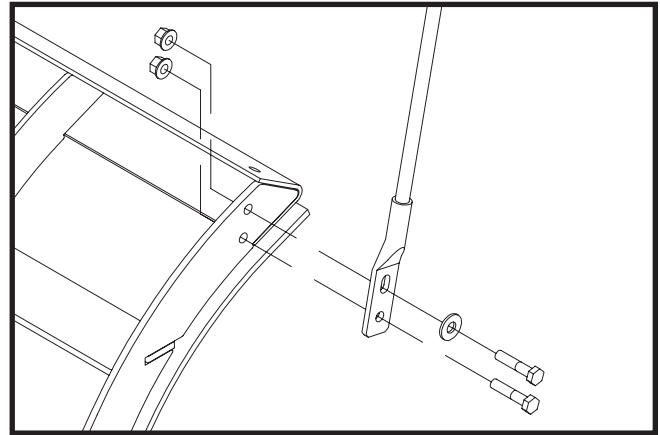

DWG. NO. 6006

NOTE: The power cable and wiring harness must be connected between the snowplow and truck to test the functions of the headlights and power unit. Vehicle ignition must be switched on.

- Move the headlight switch on the joystick controller to the "TRUCK" position and turn on the vehicle headlights. High and low beams should operate on the truck.
- Turn the vehicles headlight switch to its off position then move the switch to the "PLOW" position. Plow lights should operate in both high and low beams. Vehicle headlights should be off.
- Test the parking lights and turn signals. Lights on the plow and truck should operate at the same time.
- In an area clear of bystanders, test joystick functions by raising and lowering the plow and angling side to side.

NOTE: To reverse the angle functions, exchange the tan and gray wires on the power unit.

Refer to the section titled "Controller Configuration" for instructions on inverting the raise and lower functions.

CONTROLLER CONFIGURATION

NOTE: The 2 pin power cable and 16 pin plow harness must be connected, and the vehicle's ignition switch must be switched on in order to test the functions of the headlights and power unit.

1. Ensure the black and white 12 pin connector from the cab harness is attached to the controller.
2. Use the plow selection switch to select whether you have a V-Plow or a Straight Blade.

Model	Plow Type	Position
9585, 9595	Torsion V	Up
9863, 9963, 9710	Compression V	Up
2754, 2804, 2854	Steel Straight	Down
8804, 8904	C	Down
6814, 6914	Scoop	Down
7814, 7914	Poly Straight	Down
703, 753	Mid Size Straight	Down

NOTE: As supplied from the factory, the snow-plow controller raises the plow when the joystick is pulled backward and lowers the plow when the joystick is pushed forward. If you wish to reverse this follow steps 3 through 5. If not, skip to step 6.

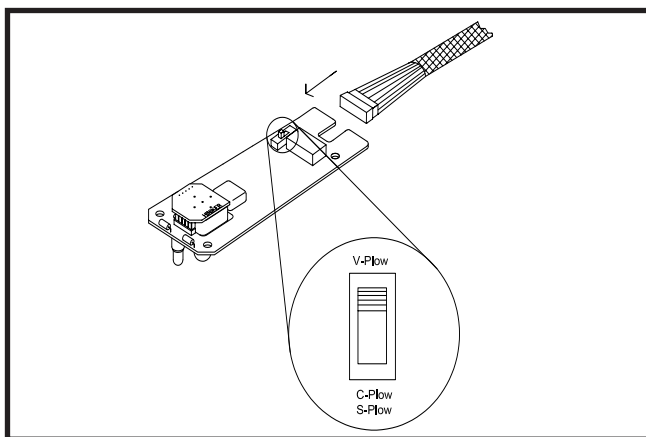

DWG. NO. 8006

3. Pry the face plate of the controller by inserting a small screwdriver along the side of the plate of the plate at location 1 in drawing 5855A. Flip the plate over, then reinstall by gently sliding the 4 tabs into the slots in the controller top.
4. To reverse the joystick switch, gently pull on the edges of the small circuit board at the base of the joystick switch to remove the switch from the 5 pins on the main circuit board.
5. Rotate the switch 90 degrees then gently push the switch back onto the 5 pins.
6. Insert the main circuit board into the case top ensuring the joystick is properly seated and the harness strain relief is inside the case.
7. Assemble the case with the provided screws.
8. Test the controller on the snow plow to verify that raise and lower functions are what the operator desires.

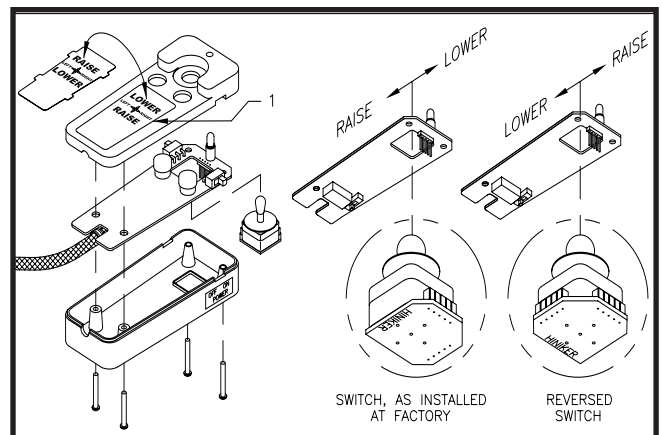

DWG. NO. 5855A

HEADLAMP AIMING PROCEDURE

NOTE: Headlamp aiming should be done while plow is in a raised position.

NOTE: This procedure should be done with no load on the vehicle other than the driver, snow-plow, and rear ballast weight, inspect the vehicle for proper tire inflation and broken or sagging suspension components. Check functioning of any automatic vehicle leveling systems and any specific manufacturer's instructions pertaining to vehicle preparation for headlamp aiming. Stabilize the suspension by rocking the vehicle sideways.

1. Park the vehicle with the plow attached on a level surface 25' (7.6 m) from a flat, unobstructed light-colored wall.
 1. Centerline of vehicle.
 2. Height of Lamp Centers.
 3. LH Headlight Center (see Table 1 for dimensions from Line 1).
 4. RH Headlight Center (see Table 1 for dimensions from Line 1).
 5. Vertical Aim Down Height (see Table 2 for dimension from Line 2)
2. Mark the wall with black tape according to drawing 5698B.
3. Wipe the lamp lenses clean and check for proper switching and function.
4. Activate the plow lamp HIGH beams to illuminate toward the wall.

5. Focus the center of the LH light beam on the intersections of lines 3 and 5.
6. Focus the center of the RH light beam on the intersections of lines 4 and 5.
7. Tighten the headlamp hardware according to the table below.

Type	Line 3 & 4 Dimension
LED	19 in (48 cm)
Halogen	22 in (56 cm)

Height from Ground	Dimension
22 to 36 in (56 to 90 cm)	0
36 to 48 in (90 to 120 cm)	2 in (5 cm)
48 to 54 in (120 to 140 cm)	4 in (6.4 cm)

Type	Size	Ft-Lbs	N-m
LED	1/2" (Bracket to Bar)	58-82	79-112
	1/4" (Light to Bracket)	6-7	8-10
Halogen	1/2" (Bracket to Bar)	58-82	79-112
	3/8" (Light to Bracket)	29-41	39-56

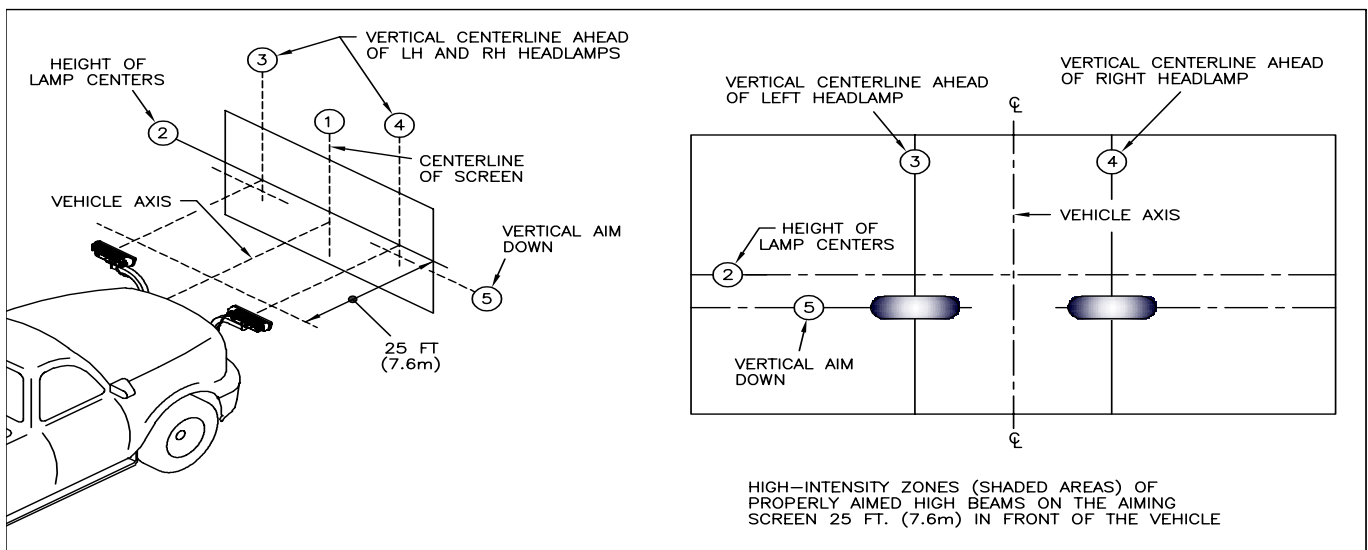

HINIKER WARRANTY

HINIKER SNOWPLOW LIMITED WARRANTY

The only warranty Hiniker Company (Hiniker) gives and the only warranty that any Hiniker dealer is authorized to give on behalf of Hiniker is as follows: **(NO EMPLOYEE OR REPRESENTATIVE IS AUTHORIZED TO CHANGE THIS WARRANTY IN ANY WAY OR GRANT ANY OTHER WARRANTY.)**

Hiniker warrants to the original purchaser of a Hiniker snowplow that Hiniker will repair or replace any defects in material and workmanship that occur within two years from date of retail delivery except the following items: Hiniker warrants that it will repair or replace any defects in materials or workmanship with respect to the paint finish, any accessories, and service parts and components for a period of one year from date of retail delivery.

Hiniker's obligation and liability under this warranty is expressly limited to repairing or replacing, at Hiniker's option, at an authorized Hiniker dealer location, the defective parts at no charge to the original purchaser. **HINIKER MAKES NO OTHER WARRANTY, EXPRESS OR IMPLIED AND MAKES NO WARRANTY OF MERCHANTABILITY OR OF FITNESS FOR ANY PARTICULAR PURPOSE.**

HINIKER'S OBLIGATION UNDER THIS WARRANTY SHALL NOT INCLUDE ANY TRANSPORTATION CHARGES TO OR FROM THE AUTHORIZED HINIKER DEALER LOCATION OR ANY LIABILITY FOR INCIDENTAL, INDIRECT OR CONSEQUENTIAL DAMAGE OR DAMAGES OF ANY KIND FOR LOST PROFITS OR DELAY. If requested by Hiniker, products or parts for which a warranty claim is made are to be returned freight prepaid to our factory. Any improper use, operation beyond rated capacity, substitution of parts not approved by Hiniker Company, or any alteration or repair in such manner as in our judgment affects the product materially and adversely shall void this warranty.

Hiniker reserves the right to make improvements or changes to any of its products without notice. Such improvements or changes shall not trigger any obligation by Hiniker to update, modify or change any products previously sold by Hiniker.

HINIKER does not warrant the following:

1. Used products.
2. Any product that has been repaired, modified or altered in a way not approved by Hiniker Company.
3. Depreciation or damage caused by normal wear, lack of reasonable and proper maintenance, failure to follow Operators Manual Instructions, misuse, lack of proper protection during storage, or accident.
4. Parts replacement and service necessitated by normal wear or maintenance including, but not limited to, cutting edges, hoses, snowplow skid shoes, blade marker guides and hardware.
5. Paint finish damage caused by normal wear.

Hiniker does not assume any liability for any damage to a motor vehicle resulting from the attachment or use of a Hiniker snowplow. Compliance with applicable motor vehicle regulations is the responsibility of the installer. Attachment of a Hiniker snowplow to a motor vehicle is at the risk of the purchaser.

It is the responsibility of the original snowplow purchaser to verify the original date of purchase.

A DELIVERY REPORT FORM must be filled out and received by Hiniker with 30 days of retail delivery at the address below to initiate the warranty coverage.

HINIKER COMPANY
58766 240th Street
Mankato, MN 56001
PHONE 800-433-5620 -- FAX (507) 625-5883
www.hiniker.com