

VEHICLE INSTALLATION INSTRUCTIONS FOR:
CHEV/GMC 4x4: 2019 & NEWER
K1500 SILVERADO/SIERRA

Hiniker Company
58766 240th St.
Mankato, MN 56001

INSTRUCTION SHEET NO: 25014010 Rev. C

April 20, 2023



IMPORTANT: Read the Snowplow Operator's Manual before assembling this kit.

Minimum Vehicle Recommendations	
- Snowplow Prep Package	REAR BALLAST - 500 lbs. when plow is attached. Secure Weight Behind Rear Axle.

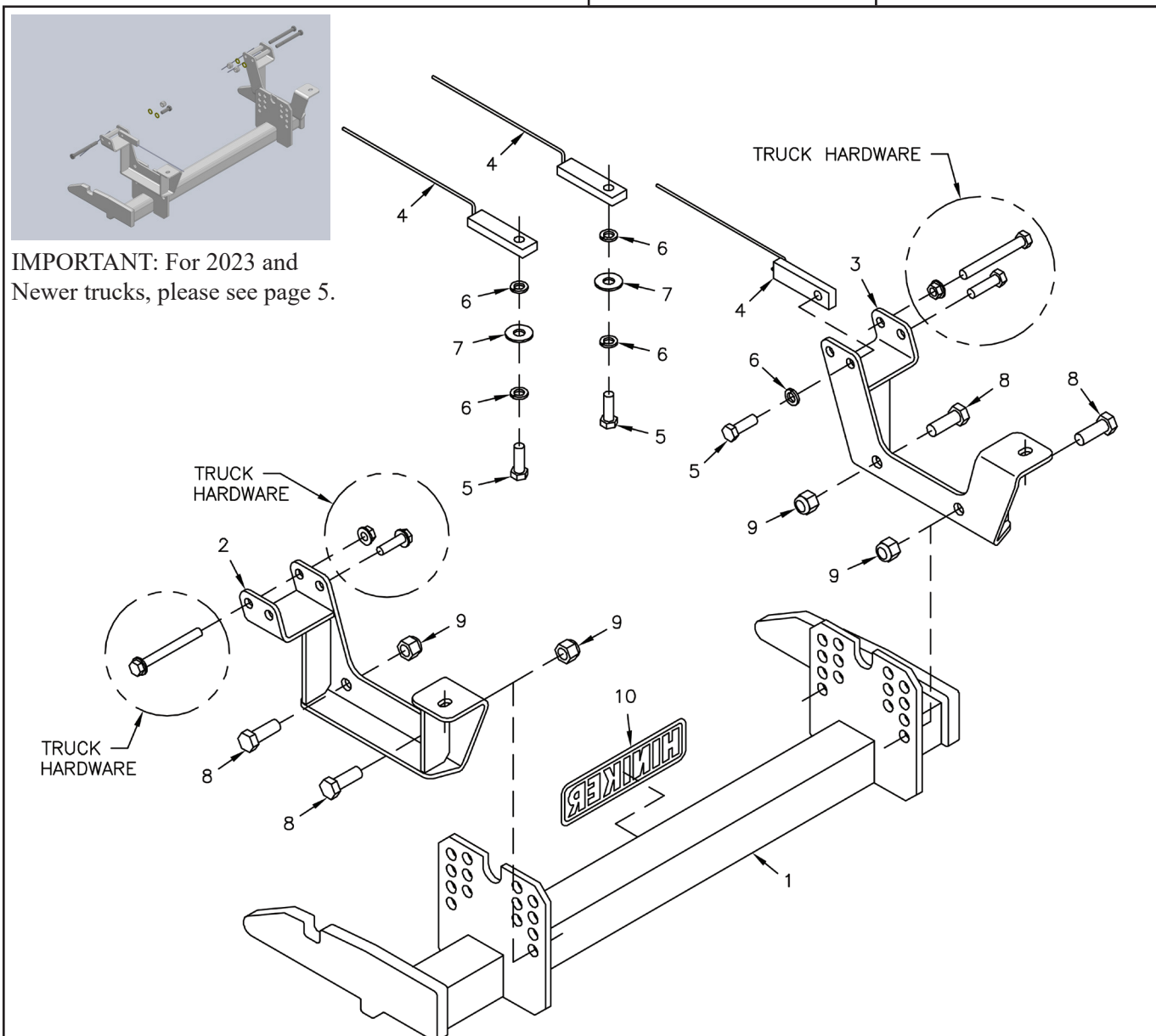

IMPORTANT: For 2023 and Newer trucks, please see page 5.

Mount Kit 25014004

DWG. NO. 7672A

REF. NO.	PART NUMBER	DESCRIPTION	QTY.	REF. NO.	PART NUMBER	DESCRIPTION	QTY.
1	25010177	Prong Weldment	1	7		Flat Washer, 1/2 Inch Hardened	2
2	25014006	LH Bracket Weldment	1	8		Hex Head Cap Screw 5/8-11 x 1 1/2 Gr. 5	4
3	25014007	RH Bracket Weldment	1	9		Lock Nut 5/8-11 Nylon Insert	4
4		Nut Bar Weldment	3	10		Hiniker Decal	1
5		Hex Head Cap Screw 1/2-13 x 1 1/2 Gr. 8	3	25014011		Bolt Bag	1
6		Lock Washer, 1/2 Inch	5				

All hardware should be tightened only enough to ensure safety during assembly. Fully tighten all hardware after entire assembly is completed.

GRADE 5 TYPE B & F LOCK NUT TORQUE VALUES

Size	Ft-lbs.	N-m
5/16"	13-18	17-25
3/8"	23-33	31-44
1/2"	58-82	79-112
5/8"	117-165	158-223

GRADE 5 BOLT TORQUE VALUES*

Size	Ft-lbs.	N-m
1/4"	8-12	11-16
3/8"	29-41	39-56
1/2"	73-103	99-140
5/8"	146-206	198-279
* Applications without lock nuts		

1. Remove both lower valance brackets from the bottom of the frame rails. These will not be reinstalled with this mount.

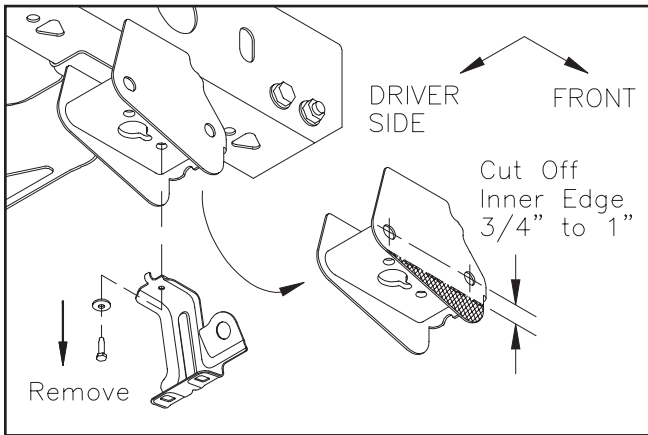

DWG. NO. 7673

Cut 3/4 to 1 inch of material from the inner face of the valance support structure, as shown in Drawing 7673, for clearance with mount brackets.

2. Remove the splash shield from the truck. Slide clip nuts out from bottom of frame rails. These will not be reused.

Prepare the splash shield for reinstallation by increasing the diameter of the two upper holes to about 7/8 to 1 inch.

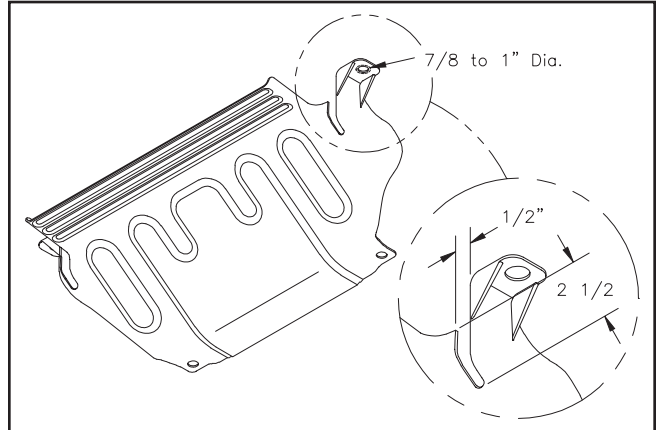

DWG. NO. 7674

Cut 1/2 inch x 2 1/2 inch slots along both front outer edges for clearance with mount brackets.

Drill two splash shield mount holes in the truck frame to 17/32 inch diameter.

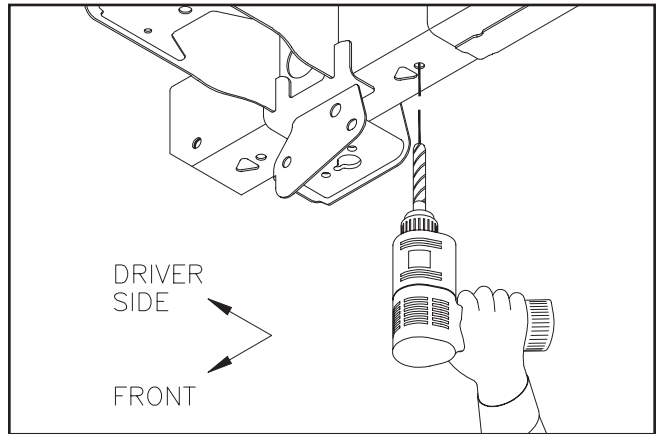

DWG. NO. 7675

3. Unbolt tow hook hardware from the front of both frame rails.

Fit LH and RH brackets to the bottom of the frame rails and reinsert tow hook hardware through frame holes to hold brackets in place.

NOTE: The outer rear hole in the driver side bracket will not be used.

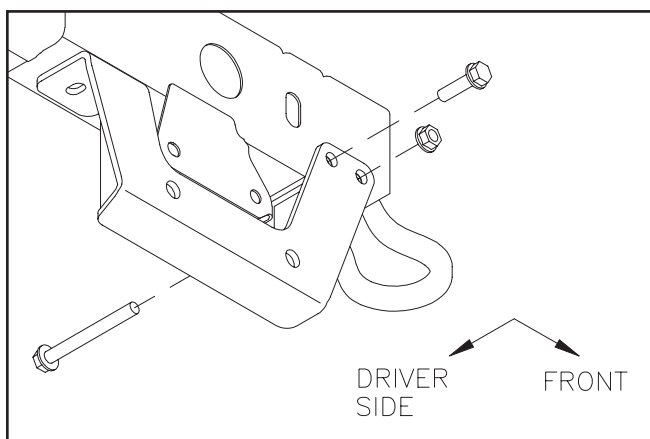

DWG. NO. 7676

4. Drill a 17/32 inch diameter hole into the passenger side frame rail through the rear inner hole of the mount bracket.

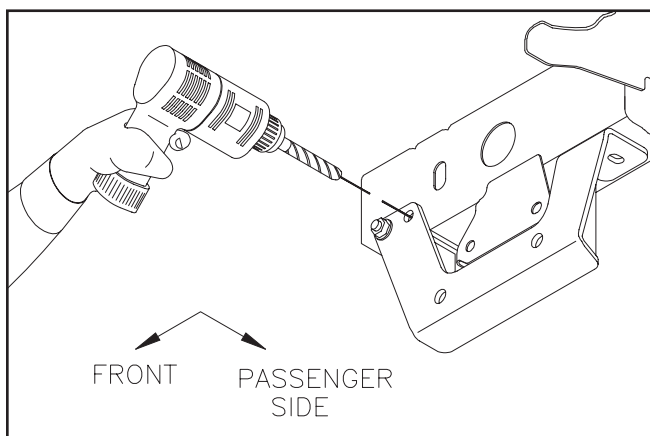

Drill Passenger Side Hole

DWG. NO. 7677

Insert a nut bar weldment into the rail to align with the drilled hole, then secure the assembly with a 1/2 inch x 1 1/2 inch hex bolt and lock washer.

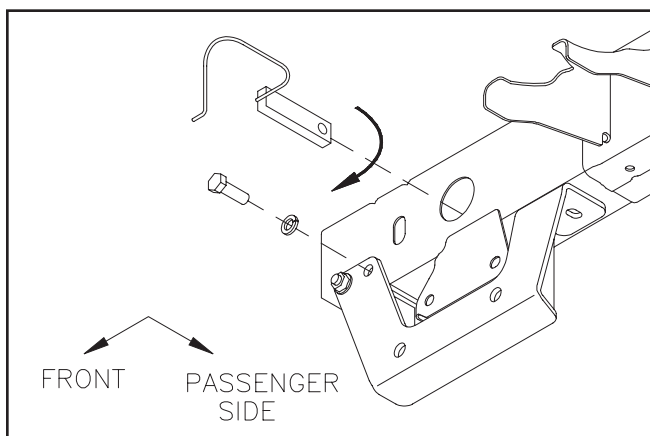

DWG. NO. 7678

5. Place the two remaining nut bars into the frame rails to align with rear holes in the mount brackets.

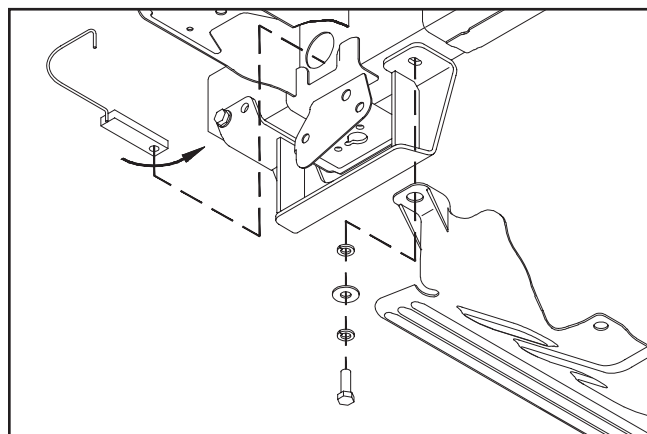

DWG. NO. 7679

Assemble two lock washers and a flat washer onto two 1/2 inch x 1 1/2 inch hex bolts as shown in drawing 7679, then fasten the two front holes in the splash shield and rear hole of the mount brackets to the truck frame.

Reassemble two bottom splash shield holes to the truck with original fasteners.

Bend wire handles of nut bars to an out of the way position.

6. Remove the plastic air dam from the bottom of the truck bumper. This will not be reinstalled.

Loosely fasten the rear holes of the prong weldment between rear holes of the side brackets with 5/8 inch x 1 1/2 inch hex bolts and lock nuts.

Swing the prong up and mark the position of the plates on the lower bumper.

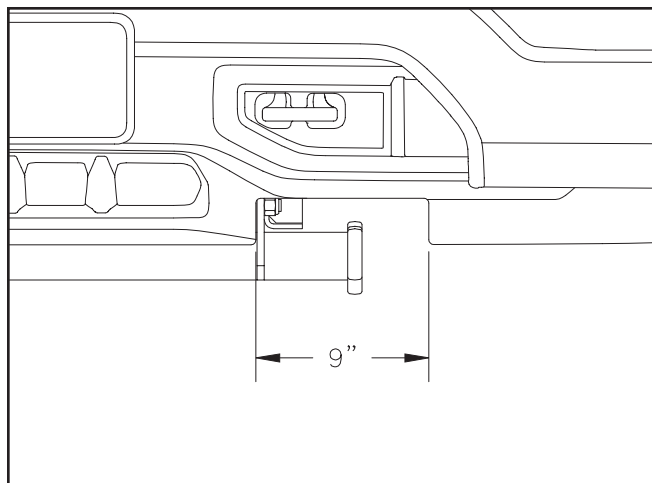

DWG. NO. 7680

Notch the bottom edge of the lower bumper about 9 inches outward from the plate positions to provide clearance for the prong receivers on the plow. Remove only the least amount of material required for clearance to preserve the appearance of the truck.

Fasten the front holes of the prong plates between the side brackets with two remaining 5/8 inch x 1 1/2 inch hex bolts and lock nuts.

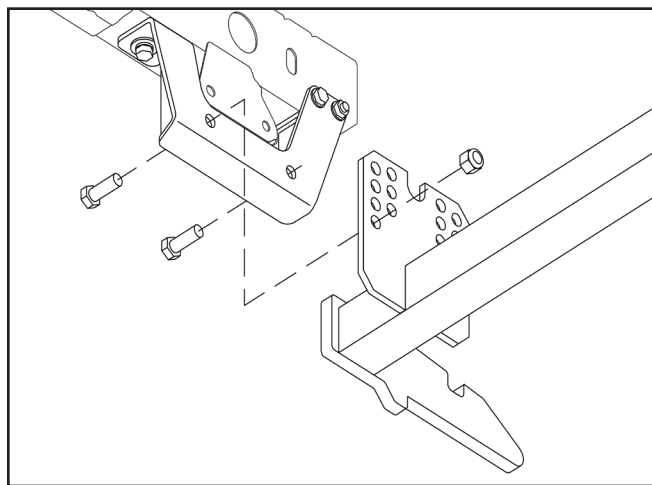

DWG. NO. 7681A

Bottom edges of the prongs should measure 9 to 10 inches above the ground.

7. Fully tighten all hardware to specified torque values.

2023 and Newer Models

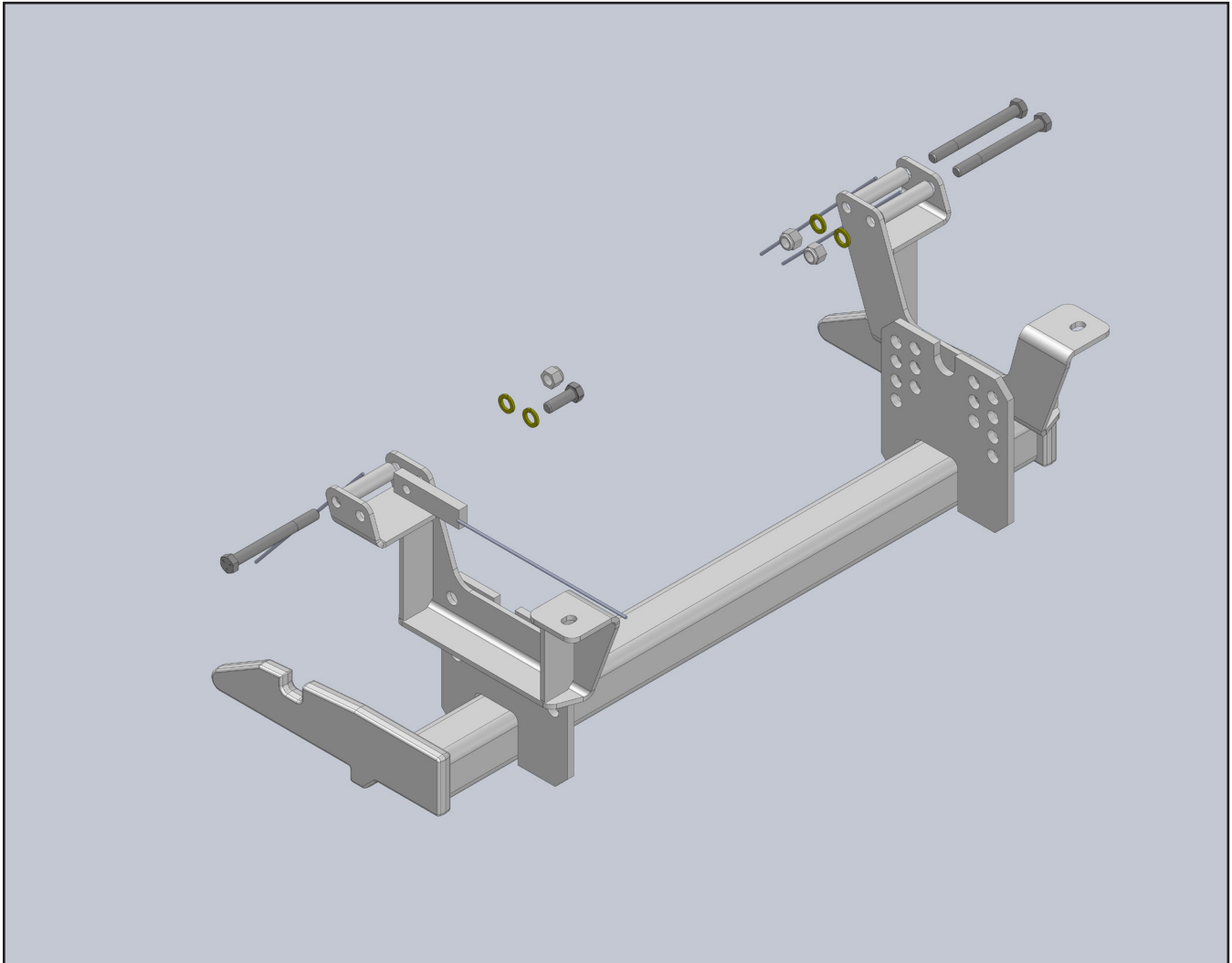

For the 2023 and newer models, the tow hook was moved on the frame. To attach mount brackets, loosen and remove tow hook bolts in order to get mount kit spacers in place. For 2022 and older models, use the tow hooks as a spacer and nut, and use existing truck hardware. The additional spacers, nut bar, and bolts will not be used.

For 2023 and newer models, use hole drilled in step 4 for through bolt, instead of nut bar and short bolt that were previously used on passenger side. Use provided 1/2-13x5 grade 5 bolts through the spacer bushings, and secure with split lock washer and nylock nut. On driver side, use provided nut bar, and 1/2-13 x 1.5 bolt.