

VEHICLE INSTALLATION INSTRUCTIONS  
DODGE 4 X 4: 1972-1993 W150-250-350

Hiniker Company  
58766 240th St.  
P.O. BOX 3407  
Mankato, MN 56002

INSTRUCTION SHEET NO: 25013186

April 5, 2012

**IMPORTANT: Read the Snowplow Operator's Manual before assembling this kit.**

MINIMUM VEHICLE RECOMMENDATIONS	REAR BALLAST - 500 lbs. when plow is attached. Secure Weight Behind Rear Wheels.
HD Alternator HD Battery HD Front Springs	

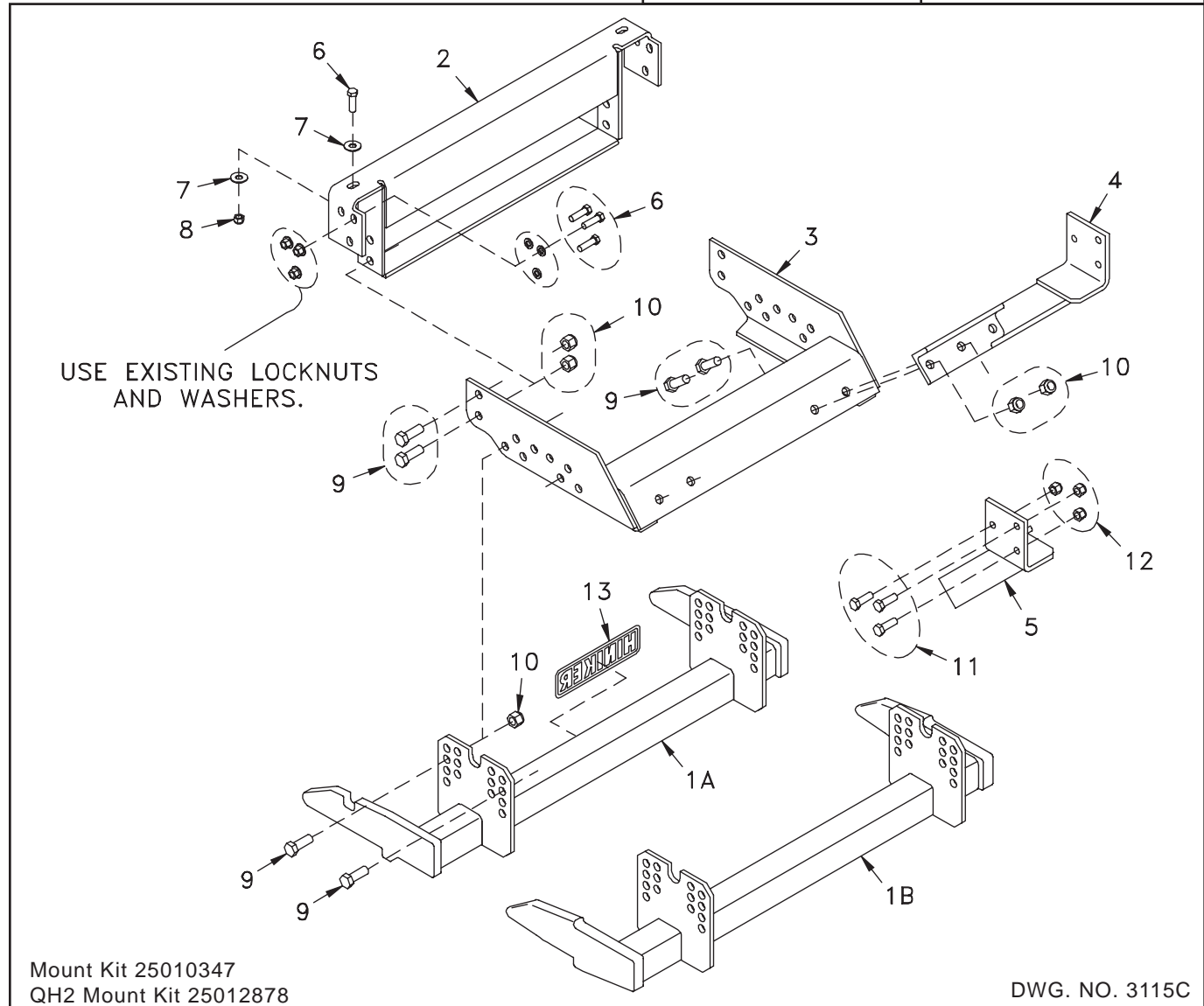

REF. NO.	PART NUMBER	DESCRIPTION	QTY.	REF. NO.	PART NUMBER	DESCRIPTION	QTY.
1A	25010177	Prong Weldment	1	8	951-003-003	Lock Nut 7/16-14 Nylon Insert	2
1B	25012896	Prong Weldment - QH2	1	9	950-001-132	Hex Head Cap Screw 5/8-11 x 1 3/4 Gr. 5	16
	25010359	Front Mount Weldment	1	10	060756	Lock Nut 5/8-11 Nylon Insert	16
3	25010355	Mount Frame Weldment	1	11	950-001-125	Hex Head Cap Screw 1/2-13 x 1 1/2 Gr. 5	6
4	25010348	RH Bracket Weldment	1	12	951-003-009	Lock Nut 1/2-13 Nylon Insert	6
5	25010352	LH Bracket Weldment	1	13	25010008	Hiniker Decal	1
6	950-001-094	Hex Head Cap Screw 7/16-14 x 1 1/2 Gr. 5	8		25011163	Bolt Bag	
7	952-002-004	Flat Washer 7/16 Inch	4				

All hardware should be tightened only enough to ensure safety during assembly. Fully tighten all hardware after entire assembly is completed.

**GRADE 5 TYPE B & F LOCK NUT TORQUES**

Size	Ft-lbs.	N-m
5/16"	13-18	17-25
3/8"	23-33	31-44
1/2"	58-82	79-112
5/8"	117-165	158-223

**GRADE 5 BOLT TORQUES\***

Size	Ft-lbs.	N-m
1/4"	8-12	11-16
3/8"	29-41	39-56
1/2"	73-103	99-140
5/8"	146-206	198-279

\* applications without lock nuts

1. Remove the front bumper and bumper mount brackets from the truck.
2. Slide the front bracket weldment over top of the vehicle rails and align the three holes in the bracket side plates with the three holes in the rails.



PHOTO NO. 3514

Bolt the front bracket weldment to the vehicle frame through the two holes in the top of the bracket, using 7/16 inch X 1 1/2 inch hex bolts, flat washers and lock nuts.

NOTE: Vehicles with bumper extensions may require a hole drilled in the extensions at location 1 before mounting the front bracket weldment on the vehicle frame. Mark hole locations in extension channels through the existing hole in

each vehicle rail, then remove extensions from the truck to drill a 17/32 inch diameter hole at the marked locations. Reassemble the extensions onto the vehicle.

3. Install washers from removed bolts onto 7/16 inch X 1 1/2 inch hex bolts supplied in kit, and reattach bumper brackets to the vehicle through holes in front bracket weldment and vehicle rails. Secure bolts with lock nuts removed from the vehicle.

NOTE: Flat washers (not supplied) may be inserted as spacers at location 2 between bumper brackets and bumper extensions.

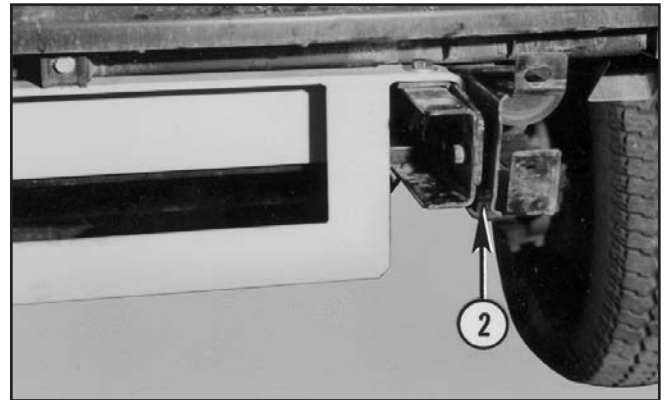

PHOTO NO. 3514A

Bolt the bumper to bumper brackets with original hardware.

4. Lift the mount frame weldment into position and bolt to the front mount weldment with 5/8 inch X 1 3/4 inch hex bolts and lock nuts.



PHOTO NO. 3515

5. Loosely fasten the LH and RH bracket weldments to the sets of holes at the rear of the mount frame weldment at location 3 with 5/8 inch X 1 3/4 inch hex bolts and lock nuts.

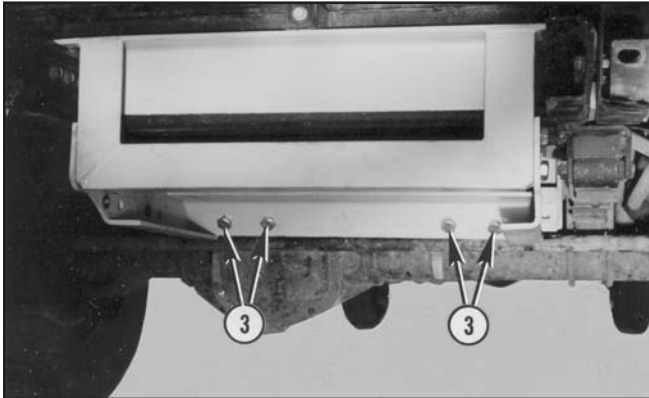

PHOTO NO. 3516

Clamp LH and RH bracket weldments to the outside and bottom of the vehicle frame and against the protruding rivet head on the outside of the rails.

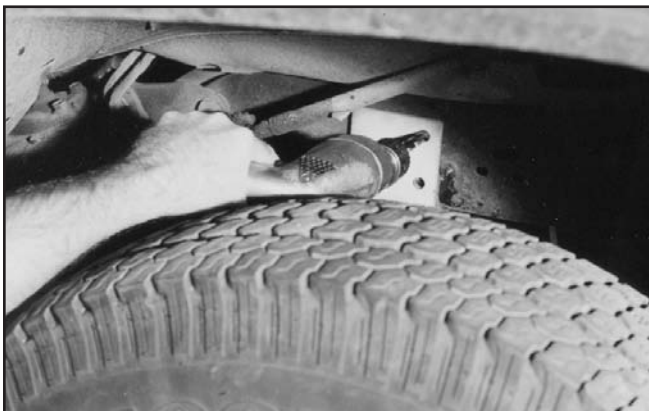

PHOTO NO. 3517

Drill three 17/32 inch diameter holes in each frame rail through existing holes in the brackets and install 1/2 inch X 1 1/2 inch hex bolts and lock nuts.



PHOTO NO. 3518

6. Bolt the prong weldment to the mount frame with 5/8 inch X 1 3/4 inch hex bolts and lock nuts.

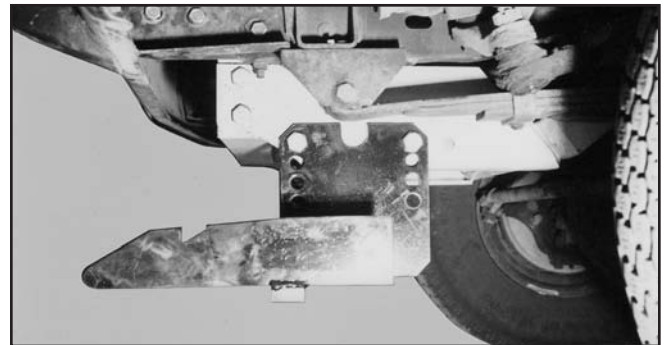

PHOTO NO. 3519

Bottom edges of the prongs should measure about 10 inches above the ground. Ideally, the prongs should lift the plow frame slightly when driving into the plow.

7. Fully tighten all hardware to specified torques.