

Hiniker Company
 58766 240th St.
 P.O. Box 3407
 Mankato, MN 56002

VEHICLE INSTALLATION INSTRUCTIONS:
 FORD F150 4 X 4: 2009 - 2010

INSTRUCTION SHEET NO: 25012704 Rev. A

August 10, 2011

 **IMPORTANT: Read the Snowplow Operator's Manual before assembling this kit.**

MINIMUM VEHICLE RECOMMENDATIONS	REAR BALLAST
- Regular Cab 4 x 4 144.5" WB, 8' pickup box, or Super Cab 4 x 4 163" WB, 8' pickup box - Snowplow Prep Package - Heavy Duty Payload Package - 5.4L V8 Engine 4R75E Automatic Transmission	- 800 lbs. When snowplow is attached. Secure weight behind rear axle.

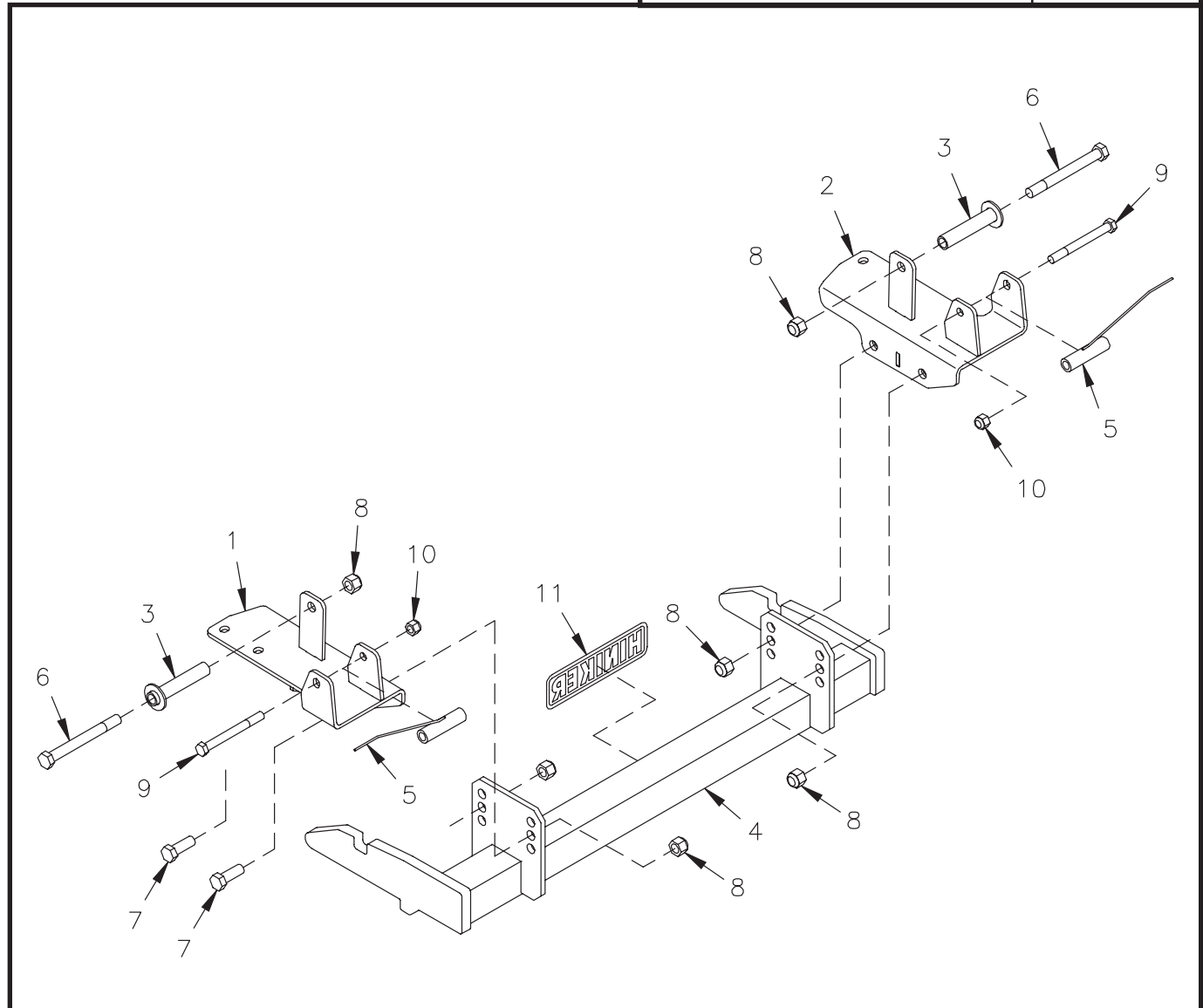

Mount Kit No. 25012702

DWG. NO. 6493

REF. NO.	PART NUMBER	DESCRIPTION	QTY.	REF. NO.	PART NUMBER	DESCRIPTION	QTY.
1	25012710	LH Bracket Weldment	1	7	950-001-132	Hex Head Cap Screw 5/8-11 x 1 3/4 Gr. 5	4
2	25012711	RH Bracket Weldment	1	8	060756	Lock Nut 5/8-11 Nylon Insert	6
3	25011519	Front Spacer Bushing Weldment	2	9	950-001-060	Hex Head Cap Screw 1/2-13 x 5 Gr. 5	2
4	25010491	Prong Weldment	1	10	951-003-009	Lock Nut 1/2-13 Nylon Insert	2
5	25011521	Rear Spacer Bushing Weldment	2	11	25010008	Hiniker Decal	1
6	950-001-161	Hex Head Cap Screw 5/8-11 x 6 Gr. 5	2		25011524	Bolt Bag	1

All hardware should be tightened only enough to ensure safety during assembly. Fully tighten all hardware after entire assembly is completed.

GRADE 5 TYPE B & F LOCK NUT TORQUE VALUES

Size	Ft-lbs.	N-m
5/16"	13-18	17-25
3/8"	23-33	31-44
1/2"	58-82	79-112
5/8"	117-165	158-223

GRADE 5 BOLT TORQUE VALUES*

Size	Ft-lbs.	N-m
1/4"	8-12	11-16
3/8"	29-41	39-56
1/2"	73-103	99-140
5/8"	146-206	198-279

* applications without lock nuts

1. Unbolt the tow hooks from the bottom of each frame rail, being careful not to damage or lose the hardware.



PHOTO NO. DCP2473

Insert bolts through holes in the tow hooks and front two holes in the LH and RH brackets from the kit, then loosely assemble brackets to the bottom of the frame rails.

2. Insert 5/8 inch x 6 inch hex bolts into the washer end of the two front spacer bushing weldments.

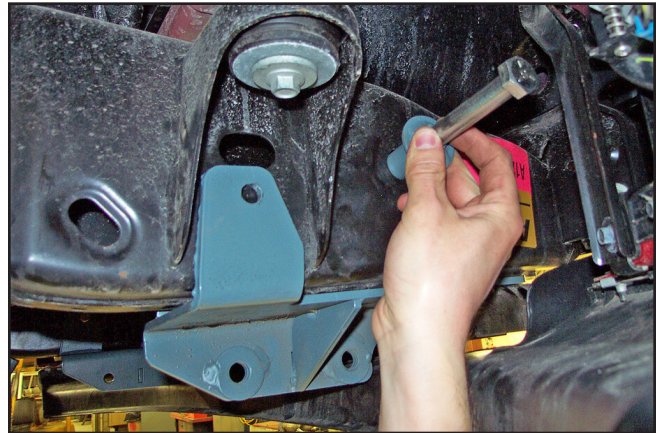

PHOTO NO. DCP2496

Install the spacers and bolts into holes through the outer walls of the vehicle rails to fasten front tabs of the LH and RH brackets to the vehicle. Secure the assembly with 5/8 inch lock nuts threaded onto the bolts.

3. Drill a 17/32 inch diameter hole into the outer wall of the frame rail on the passenger side of the vehicle. Use the hole in the rear tab of the RH bracket for a guide.

Frame holes on the driver side of the vehicle are in line.



PHOTO NO. DCP2462

Insert a rear spacer bushing from the kit into the slotted hole in the vehicle frame above the rear tab. Bend an offset into the handle of the spacer so that the bushing is in line with holes in the frame.

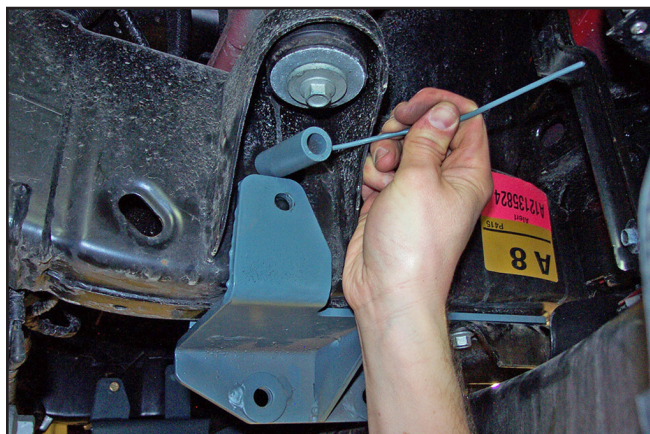

PHOTO NO. DCP2460

Install a 1/2 inch x 5 inch hex bolt through the frame rails and spacers to fasten the rear tabs of the LH and RH brackets to the vehicle. Secure the assemblies with 1/2 inch lock nuts.

Bend wire handles on spacers to an out of the way position.

5. Fasten the mount plates of the prong weldment to holes in the LH and RH brackets with four 5/8 inch x 1 3/4 inch hex bolts and lock nuts.

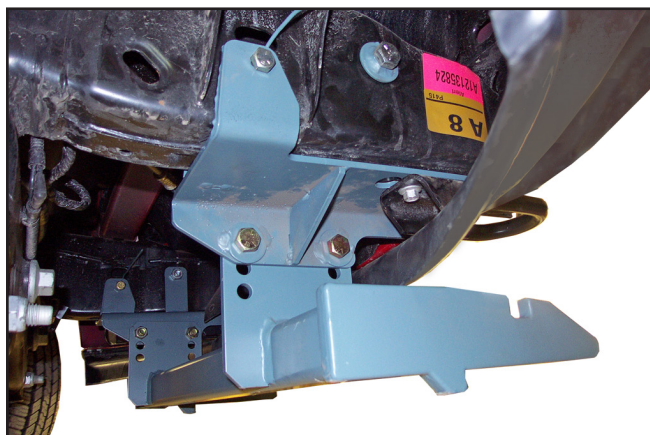

PHOTO NO. DCP2450

Bottom edges of the prongs should measure about 10 inches above the ground. Ideally, the prongs should lift the plow frame slightly when driving into the plow.

6. Fully tighten hardware to specified torque values.
7. Trim the air dam near each prong in the approximate area shown to provide clearance for the prong receivers on the plow frame.



PHOTO NO. DCP2457