

Hiniker Company
 58766 240th St.
 P.O. Box 3407
 Mankato, MN 56002

VEHICLE INSTALLATION INSTRUCTIONS:
 DODGE RAM 1500 4X4: 2002 - 2008

INSTRUCTION SHEET NO: 25011978 Rev. A

August 18, 2009



IMPORTANT: Read the Snowplow Operator's Manual before assembling this kit.

REAR BALLAST -
 500 lbs. when plow is attached.
 Secure Weight Behind Rear
 Wheels.

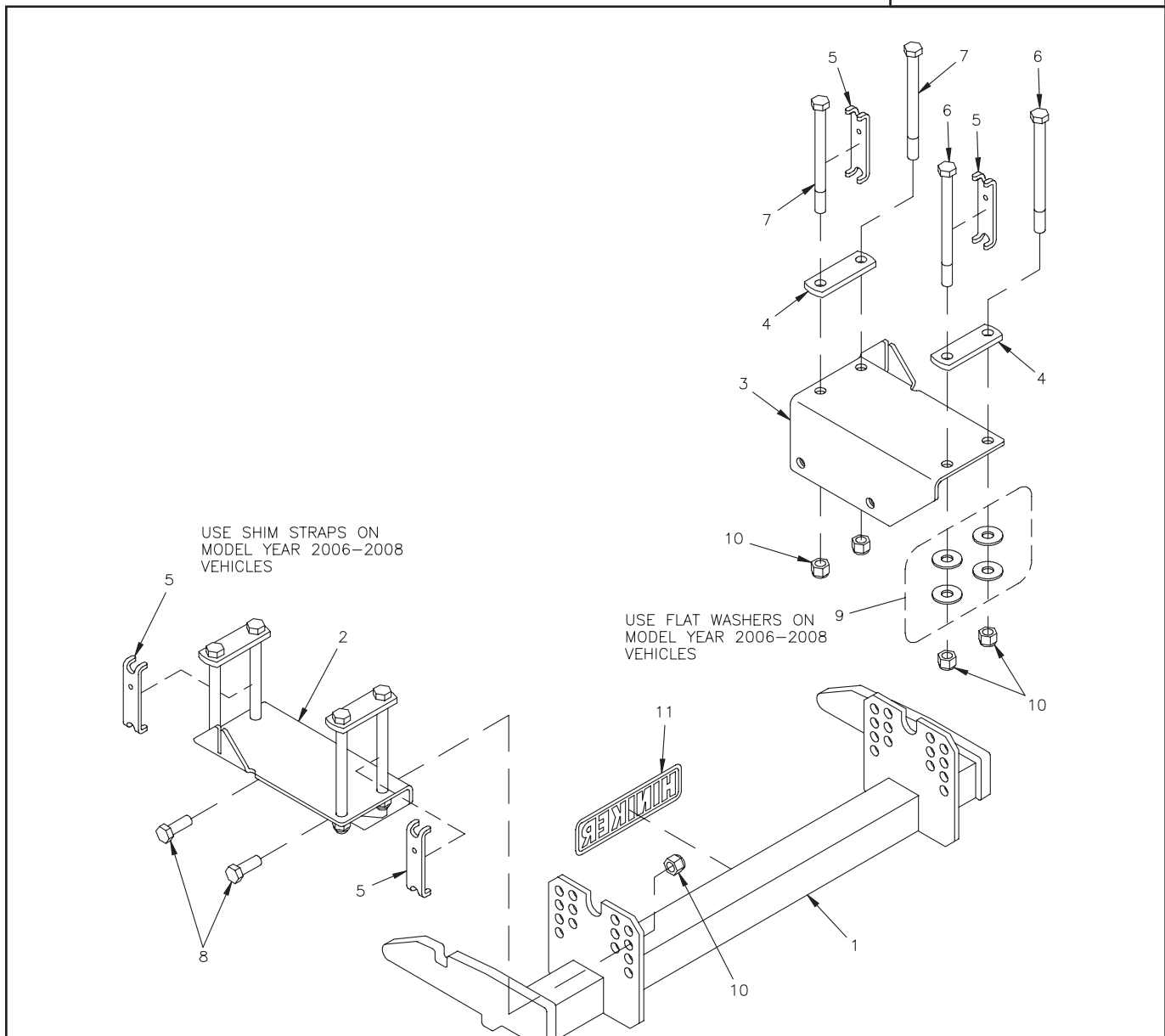

25011815 Mount Kit

DWG. NO. 5747

REF. NO.	PART NUMBER	DESCRIPTION	QTY.	REF. NO.	PART NUMBER	DESCRIPTION	QTY.
1	25010177	Prong Weldment	1	7	950-001-165	Hex Head Cap Screw 5/8-11 x 7 1/2 Gr. 5	4
2	25011971	LH Bracket Weldment	1	8	950-001-132	Hex Head Cap Screw 5/8-11 x 1 3/4 Gr. 5	4
3	25011970	RH Bracket Weldment	1	9	952-002-007	Flat Washer, 5/8 Inch	8
4	25011972	Top Bar	4	10	060756	Lock Nut 5/8-11 Nylon Insert	12
5	25011973	Shim Strap	4	11	25010008	Hiniker Decal	1
6	950-001-238	Hex Head Cap Screw 5/8-11 x 8 Gr. 5	4		25011979	Bolt Bag	1

All hardware should be tightened only enough to ensure safety during assembly. Fully tighten all hardware after entire assembly is completed.

GRADE 5 TYPE B & F LOCK NUT TORQUES

Size	Ft-lbs.	N-m
5/16"	13-18	17-25
3/8"	23-33	31-44
1/2"	58-82	79-112
5/8"	117-165	158-223

GRADE 5 BOLT TORQUES*

Size	Ft-lbs.	N-m
1/4"	8-12	11-16
3/8"	29-41	39-56
1/2"	73-103	99-140
5/8"	146-206	198-279

* applications without lock nuts

1. Insert pairs of 5/8 inch x 7 1/2 inch and 5/8 inch x 8 inch hex bolts through holes in four 1/2 inch thick top bars from the kit.

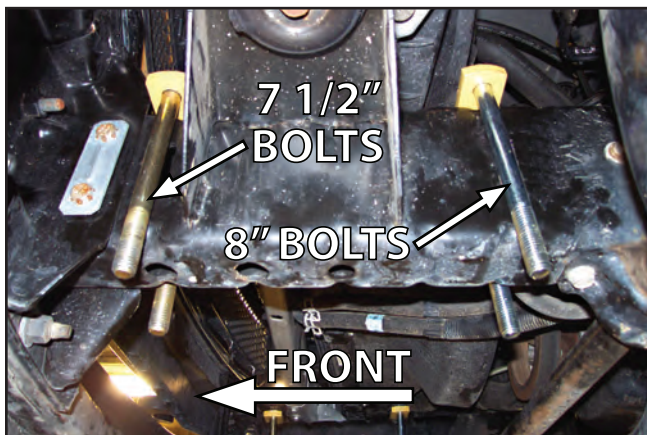

PHOTO NO. 9699

Place the 7 1/2 inch bolt/bar assemblies over the side rails of the vehicle ahead of the cab mount structure. Place the 8 inch bolt/bar assemblies over the side rails behind the cab mount structure.

2. Lift the LH and RH bracket weldments to the bottom of the corresponding frame rail and push four bolt ends through holes in the bracket.

The front edge of the cab mount structure will fall within the notch in the bracket when

the bracket is positioned correctly front to back.



PHOTO NO. 9694

Loosely thread four 5/8 inch lock nuts onto the bolt ends to hold the brackets in place.

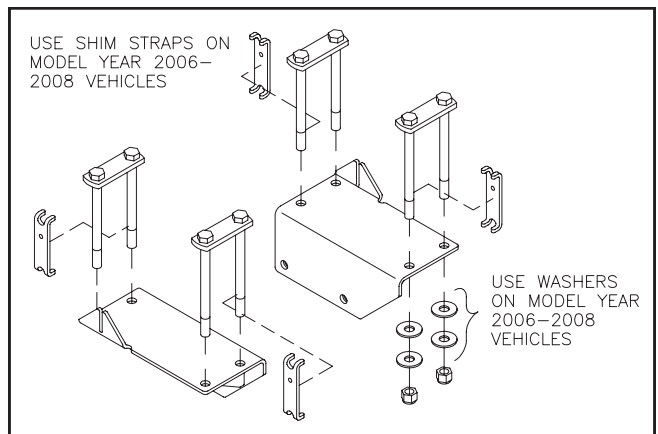

DWG. NO. 5748

Model year 2006 and later trucks have smaller frame rail cross sections that require additional hardware when installing this kit.

Insert shim straps between the inner sets of bolts and the frame rails to eliminate lateral slack.

Install two 5/8 inch flat washers under lock nuts on the four 8 inch long bolts to compensate for shorter rail heights.

3. Fasten the mount plates of the prong weldment to holes in the LH and RH brackets with four 5/8 inch x 1 3/4 inch hex bolts and lock nuts.



PHOTO NO. 9690

Bottom edges of the prongs should measure about 10 inches above the ground. Ideally the prongs should lift the plow frame slightly when driving into the plow.

4. Fully tighten all mount kit hardware to specified torque values.
5. Loosen the bumper mounting hardware, then push the bumper to its highest position before retightening to create maximum clearance for the plow mount.

In some instances the plastic trim along the bottom of the bumper must be notched or removed to provide clearance for the plow mount.

HEADLIGHT REMOVAL

The following instructions are reprinted from the 2003 Dodge Ram owner's manual. Follow these instructions when installing the mount kit headlight adapters.

1. Remove the two (2) expanding fasteners from the headlight welt.

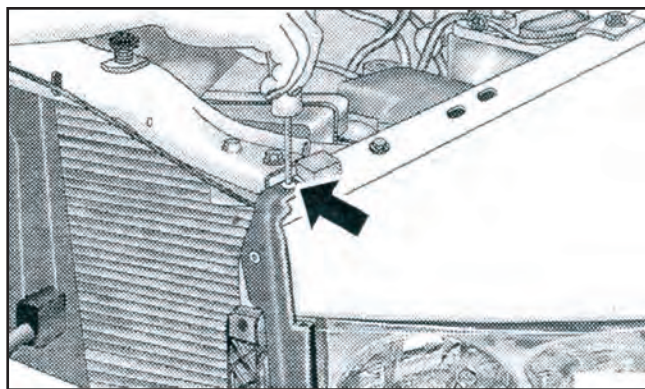

2. Remove the three (3) bolts from the headlight housing.

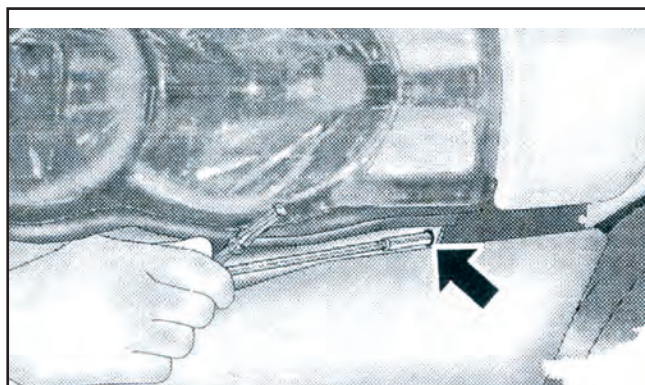
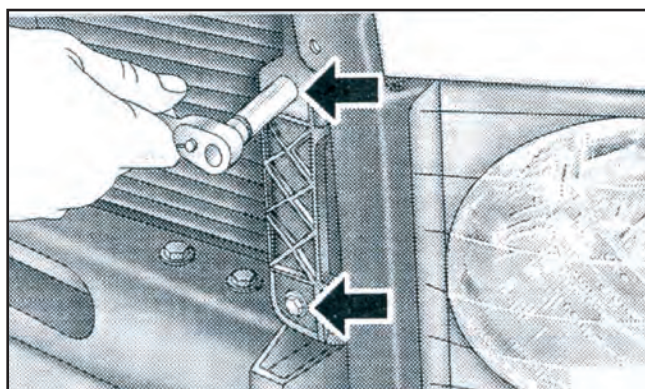
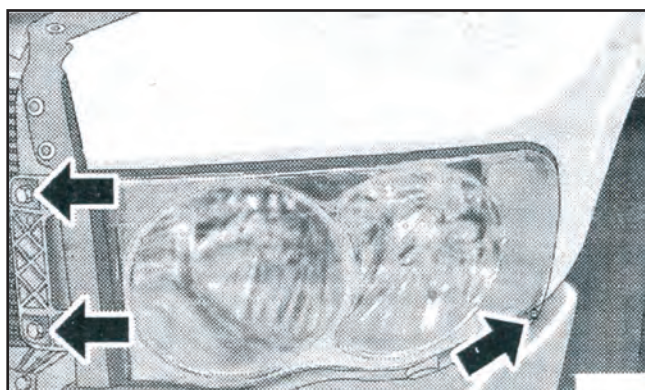

(over)

3. Pull the housing out from the fender to allow room to disconnect the electrical connectors.

