

VEHICLE INSTALLATION INSTRUCTIONS
 FORD 4 X 4: 1992-1996 F150

Hiniker Company
 58766 240th St.
 P.O. BOX 3407
 Mankato, MN 56002

INSTRUCTION SHEET NO: 25010306 REV. C

April 18, 2012



IMPORTANT: Read the Snowplow Operator's Manual before assembling this kit.

MINIMUM VEHICLE RECOMMENDATIONS	
MFR Snowplow Prep Package HD Alternator HD Battery HD Front Springs	REAR BALLAST - 500 lbs. when plow is attached. Secure Weight Behind Rear Wheels.

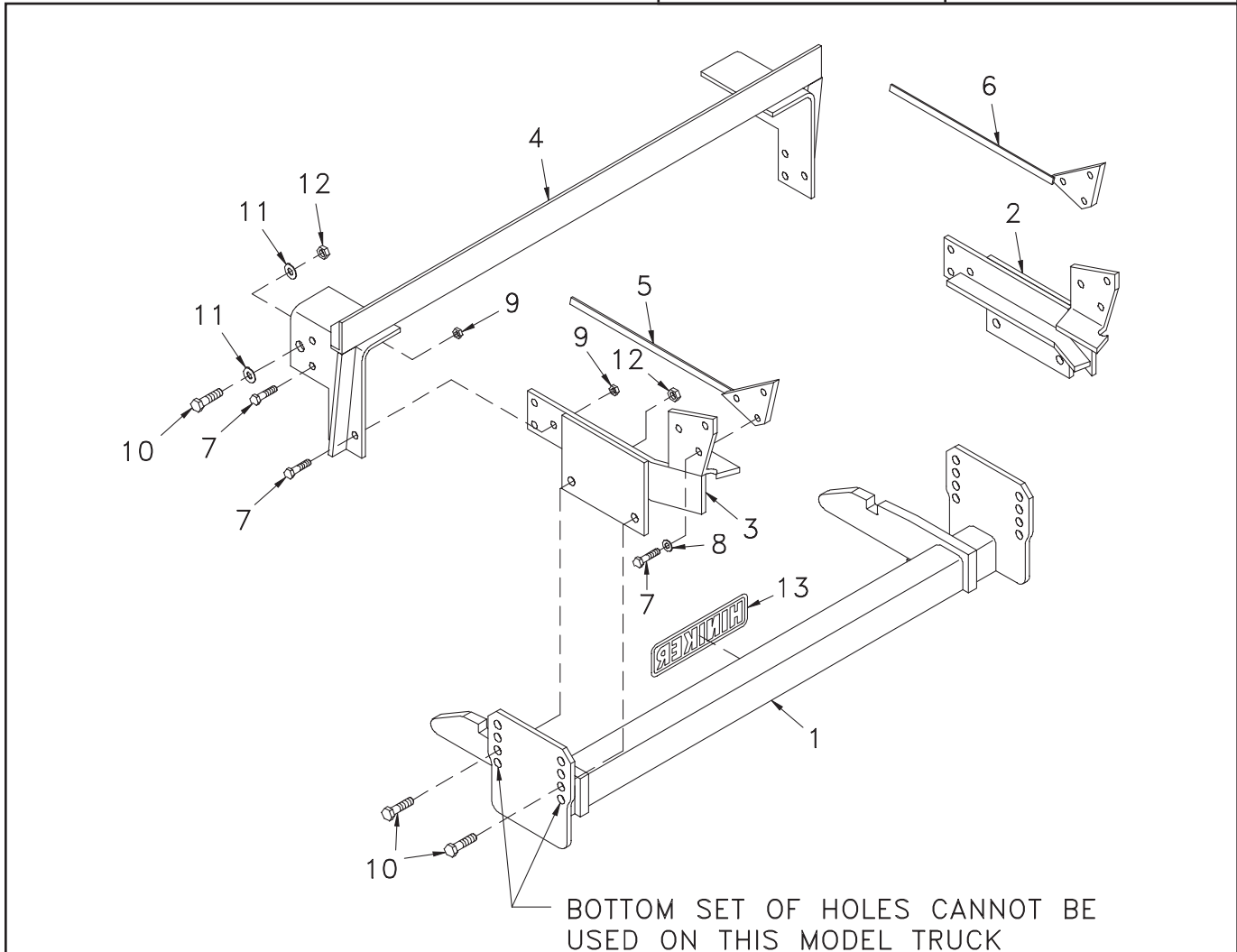

Mount Kit No. 25010254

DWG NO. 3069A

REF. NO.	PART NUMBER	DESCRIPTION	QTY.	REF. NO.	PART NUMBER	DESCRIPTION	QTY.
1	25010150	Prong Weldment	1	8	952-001-004	Lock Washer, 1/2 Inch	6
2	25010157	RH Side Bracket Weldment	1	9	951-003-009	Lock Nut 1/2-13 Nylon Insert	10
3	25010158	LH Side Bracket Weldment	1	10	950-001-132	Hex Head Cap Screw 5/8-11 X 1 3/4 Gr. 5	6
4	25010165	Front Mount Weldment	1	11	952-002-007	Flat Washer, 5/8 Inch	4
5	25010152	LH Nut Weldment	1	12	060756	Lock Nut 5/8-11 Nylon Insert	6
6	25010151	RH Nut Weldment	1	13	25010008	Hiniker Decal	1
7	950-001-125	Hex Head Cap Screw 1/2-13 X 1 1/2 Gr. 5	16		25011170	Bolt Bag	1

All hardware should be tightened only enough to ensure safety during assembly. Fully tighten all hardware after entire assembly is completed.

GRADE 5 TYPE B & F LOCK NUT TORQUES

Size	Ft.-lbs.	N-m
5/16"	13-18	17-25
3/8"	23-33	31-44
1/2"	58-82	79-112
5/8"	117-165	158-223

GRADE 5 BOLT TORQUES*

Size	Ft.-lbs.	N-m
1/4"	8-12	11-16
3/8"	29-41	39-56
1/2"	73-103	99-140
5/8"	146-206	198-279

* applications without lock nuts

1. Remove the front bumper from the truck.
2. Clamp LH and RH side mounts tight to the outside and bottom of the vehicle frame, and against the protruding rivet from the bottom of the rails. On trucks without protruding rivets, locate mounts to the front edge of 1/2 inch holes in bottom of vehicle side rails.



PHOTO NO. 3461

Drill three 17/32 inch diameter holes in each vehicle frame through existing holes in the side mount plates.

3. Identify LH and RH nut bars.

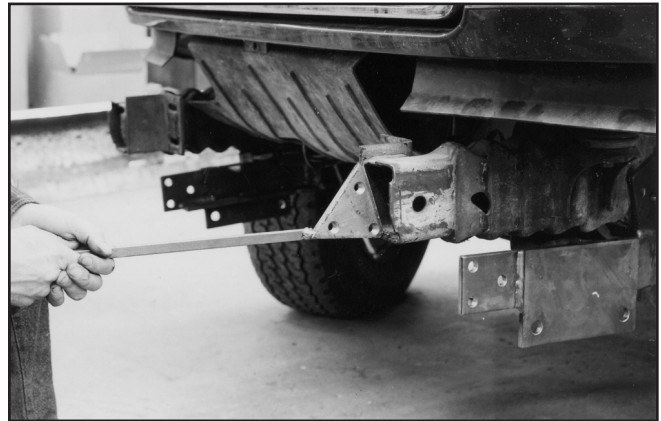

PHOTO NO. 3462



PHOTO NO. 3463

Insert nut bars into vehicle rails to match drilled holes. Bolt side mounts in place with 1/2 inch X 1 1/2 inch hex bolts and 1/2 inch lock washers.

- Carefully slip front mount bracket over top of vehicle rails and bolt to side mounts with three 1/2 inch X 1 1/2 inch hex bolts and lock nuts per side at location 1.

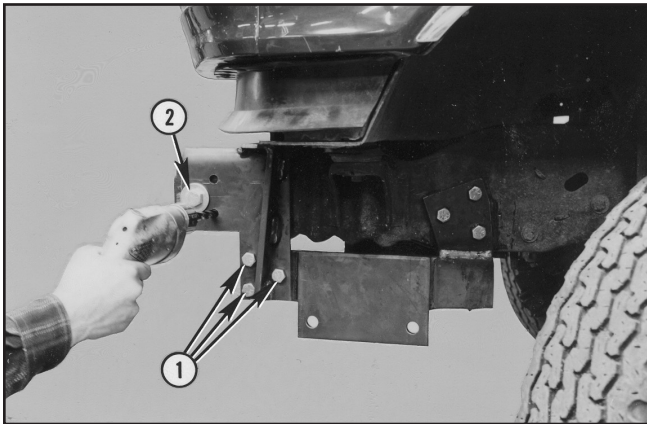

PHOTO NO. 3464

Install 5/8 inch X 1 3/4 inch hex bolts through front holes of bracket and existing holes in vehicle rails at location 2, using a flat washer under each bolt head and a flat washer and lock washer under each lock nut. Drill two 17/32 inch diameter holes in each vehicle rail through existing holes in the bracket and install 1/2 inch X 1 1/2 inch hex bolts and lock nuts.

- Fasten mount plates of prong weldment to holes in side mounts with 5/8 inch X 1 3/4 inch hex bolts.

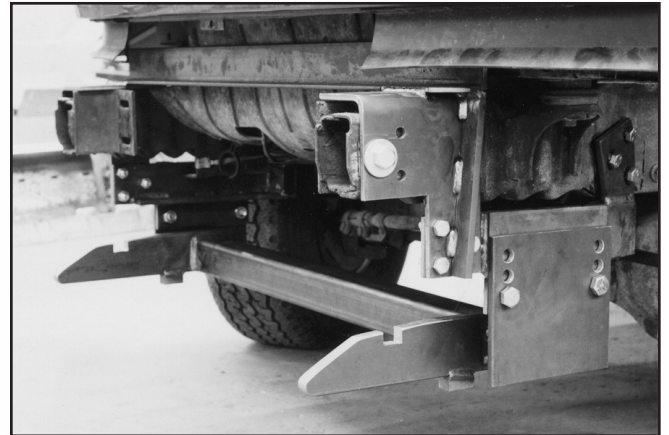

PHOTO NO. 3465

Bottom edges of the prongs should measure about 9 inches above the ground. Ideally, the prongs should lift the plow frame slightly when driving into the plow.



PHOTO NO. 3466

- Fully tighten all hardware.
- Reattach bumper onto truck with original hardware.