

# SECTION 2

# POLY V-PLOW

FOR SERIES 9850 AND 9950 V-PLOWS

## PLOW COMPONENTS

- PAGE 2 MOLDBOARD ASSEMBLIES
- PAGE 4 QUADRANT/PUSH FRAME ASSEMBLY
- PAGE 5 LIFT FRAME ASSEMBLY
- PAGE 6 POWER UNIT COVER ASSEMBLY  
1/2" THICK CUTTING EDGE
- PAGE 7 RUBBER SNOW DEFLECTOR KITS  
POLY SNOW DEFLECTOR KITS
- PAGE 8 WEAR PLATE KIT  
CURB GUARD KITS

## HYDRAULIC COMPONENTS

- PAGE 9 HYDRAULIC OVERVIEW  
1 3/4 X 9 LIFT CYLINDER
- PAGE 10 POWER UNIT - SPX MODEL DB-5245-1
- PAGE 11 POWER UNIT - MTE MODEL S203T-5051
- PAGE 12 1 3/4 X 10 ANGLE CYLINDER

## ELECTRICAL COMPONENTS

- PAGE 12 JOYSTICK CONTROLLER
- PAGE 13 UNDERHOOD WIRING HARNESS  
MOTOR SOLENOID
- PAGE 14 POWER CABLES  
PLOW WIRING HARNESS
- PAGE 15 HEADLAMPS  
GRILL MOUNT PLATE

MOLDBOARD ASSEMBLIES

SEC  
2

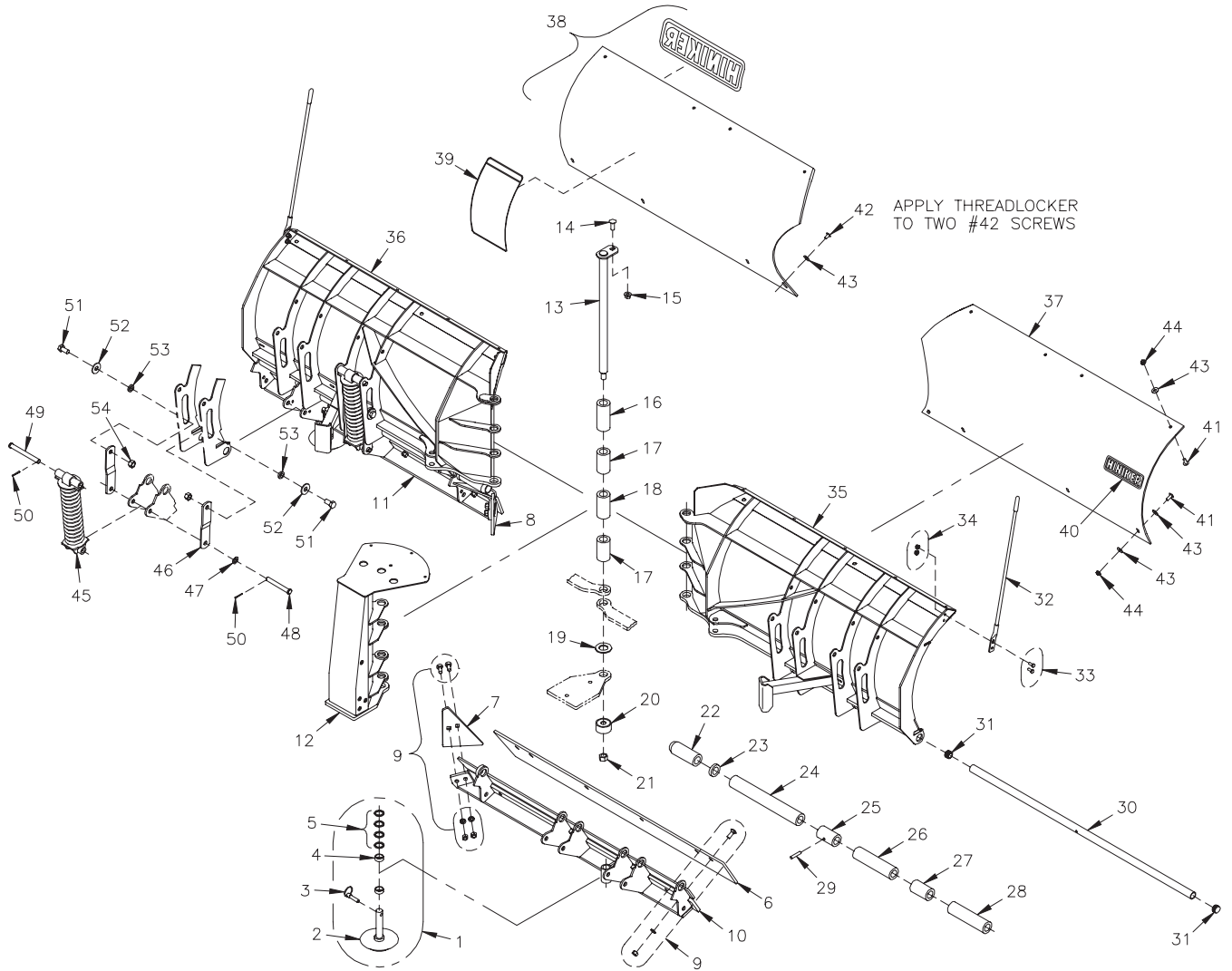

POLY V-PLOW 9850-9950

REF. NO.	PART NUMBER	DESCRIPTION	QTY.	REF. NO.	PART NUMBER	DESCRIPTION	QTY.
1	25012297	Skid Assembly	2	29	30009024	Slotted Spring Pin 3/8 x 2	2
2	25012316	Cast Skid Shoe	2	30	25012381	Trip Pin 8 1/2' Plow	2
3	25010319	Lynch Pin	2		25012323	Trip Pin 9 1/2' Plow	2
4	25010048	1/2" Spacer	4	31	25012375	End Cap	4
5	952-004-071	Machinery Bushing	8	32	25010118	Blade Guide	2
6	25012272	49 5/8" Cutting Edge, 8 1/2' Plow	2	33	950-001-110	Hex Head Cap Screw 5/16-18 x 1 Gr. 5	4
	25012273	55 5/8" Cutting Edge, 9 1/2' Plow	2	34	951-005-036	Lock Nut 5/16-18 Mac Lock	4
7	25012310	RH Center Cutting Edge Plate	1	35	25012376	RH Wing Frame Weldment, 8 1/2' Plow	1
8	25012311	LH Center Cutting Edge Plate	1		25012313	RH Wing Frame Weldment, 9 1/2' Plow	1
9	25012296	Cutting Edge Bolt Kit	1	36	25012377	LH Wing Frame Weldment, 8 1/2' Plow	1
10	25012378	RH Trip Edge Weldment, 8 1/2' Plow	1		25012312	LH Wing Frame Weldment, 9 1/2' Plow	1
	25012315	RH Trip Edge Weldment, 9 1/2' Plow	1	37	25012380	Poly Moldboard Blank, 8 1/2' Plow	1
11	25012379	LH Trip Edge Weldment, 8 1/2' Plow	1		25012322	Poly Moldboard Blank, 9 1/2' Plow	1
	25012314	LH Trip Edge Weldment, 9 1/2' Plow	1	38	25012295	Poly Blank/Logo Decal Assembly, 8 1/2' Plow	1
12	25012307	Center Mast Weldment	1		25012298	Poly Blank/Logo Decal Assembly, 9 1/2' Plow	1
13	25012304	Hinge Pin Weldment	1	39	25012270	Decal-Removal	1
14	030-16130	Carriage Bolt 1/2-13 x 1 Gr. 5	1	40	25011684	Decal-Hiniker	1
15	951-005-055	Lock Nut 1/2-13 Mac Lock	1	41	700-11704	Machine Screw 3/8-16 x 1 Slotted Truss Head	14
16	25012301	Bushing, 4 11/16" Long	1	42	950-004-108	Machine Screw 3/8-16 x 3/4 Slotted Truss Head	2
17	25011442	Bushing, 3 17/32" Long	2	43	952-002-013	Flat Washer 3/8 Inch, Stainless Steel	22
18	25012302	Bushing 4" Long	1	44	951-005-003	Lock Nut 3/8-16 Mac Lock	14
19	033-11017	Flat Washer, 1 1/4 Inch SAE	1	45	25011373	Spring Assembly	4
20	25012303	Washer Weldment	1	46	25012306	Strap	8
21	951-005-037	Lock Nut 3/4-10 2-Way	1	47	952-004-040	Machinery Bushing 21/32 x 1 1/8 x .048	4
22	25012317	Bushing 5 3/8" Long	2	48	953-002-049	Clevis Pin 5/8 x 4 3/4	4
23	25011342	Bushing 13/32" Long	2	49	953-002-045	Clevis Pin 5/8 x 6	4
24	25012651	Bushing 14 7/16" Long	2	50	035-42033	Cotter Pin 5/32 x 1 1/4	8
25	25011341	Bushing 3 3/8" Long, Steel	2	51	031-06302	Hex Head Cap Screw 5/8-11 x 1 1/4 Gr. 5	8
26	25011441	Bushing 7 29/32" Long, 8 1/2' Plow	2	52	952-002-007	Flat Washer 5/8 Inch	8
	25012319	Bushing 13 29/32" Long, 9 1/2' Plow	2	53	25012305	Bushing	8
27	25011338	Bushing, 3 3/8" Long	2	54	951-005-044	Lock Nut 5/8-11 2-Way	8
28	25012320	Bushing, 7 5/8" Long	2				

SECTION 2

PUSHFRAME ASSEMBLY

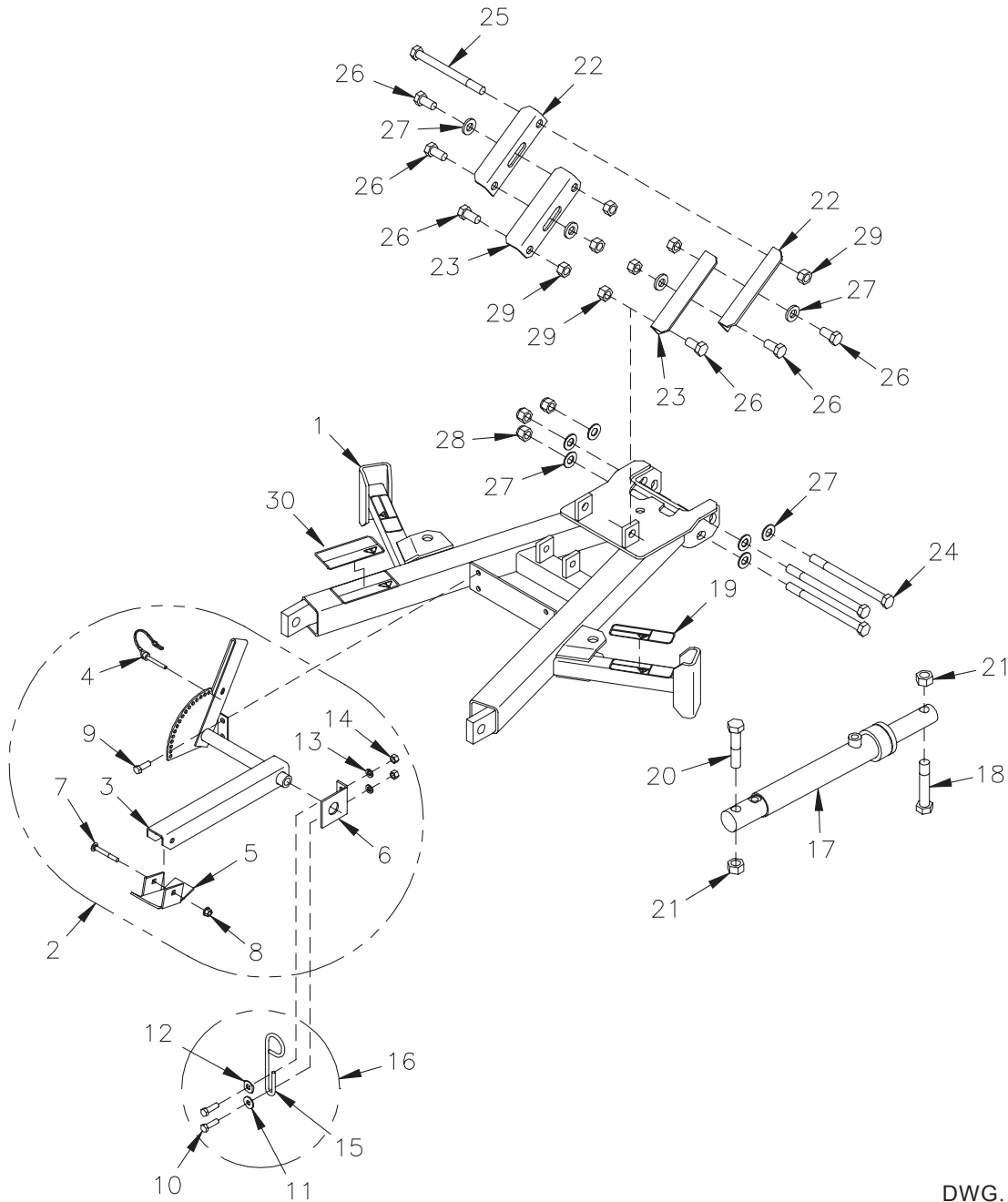

DWG. NO. 6128

REF. NO.	PART NUMBER	DESCRIPTION	QTY.	REF. NO.	PART NUMBER	DESCRIPTION	QTY.
1	25012294	Push Frame/Decal Assembly	1	16	25011076	Hose Loop Kit	1
2	25012293	Park Stand Kit	1	17	25012046	1 3/4 x 10 Cylinder (See Sec. 2, Page 12)	2
3	25012398	Park Stand Weldment	1	18	950-001-174	Hex Head Cap Screw 3/4-10 x 3 1/2 Gr. 5	2
4	25010797	Tab Lock Pin	1	19	25012271	Warning Decal	2
5	25010801	Stand Foot	1	20	950-001-069	Hex Head Cap Screw 3/4-10 x 3 1/4 Gr. 5	2
6	25010798	Bracket	1	21	951-005-037	Lock Nut 3/4-10 2-Way	4
7	950-003-074	Carriage Bolt 5/16-18 x 2 1/2 Gr. 5	1	22	25012286	Upper Angle Brace	2
8	951-005-036	Lock Nut 5/16-18 Mac Lock	1	23	25012287	Lower Angle Brace	2
9	950-001-204	Hex Head Cap Screw 3/8-16 x 7/8 Gr. 5	2	24	950-001-238	Hex Head Cap Screw 5/8-11 x 8 Gr. 5	3
10	950-001-106	Hex Head Cap Screw 3/8-16 x 1 1/4 Gr. 5	2	25	950-001-143	Hex Head Cap Screw 5/8-11 x 7 Gr. 5	1
11	952-002-003	Flat Washer 3/8 Inch	1	26	031-06302	Hex Head Cap Screw 5/8-11 x 1 1/4 Gr. 5	6
12	25011074	Flanged Washer 3/8 Inch	1	27	952-004-070	Flat Washer 5/8 Inch SAE Hardened	10
13	952-001-007	Lock Washer 3/8 Inch	4	28	060756	Lock Nut 5/8-11 Nylon Insert	3
14	951-001-005	Hex Nut 3/8-16	4	29	951-005-044	Lock Nut 5/8-11 2-Way	7
15	25011075	Hose Loop	1	30	25010697	Caution Decal	1

LIFT FRAME ASSEMBLY

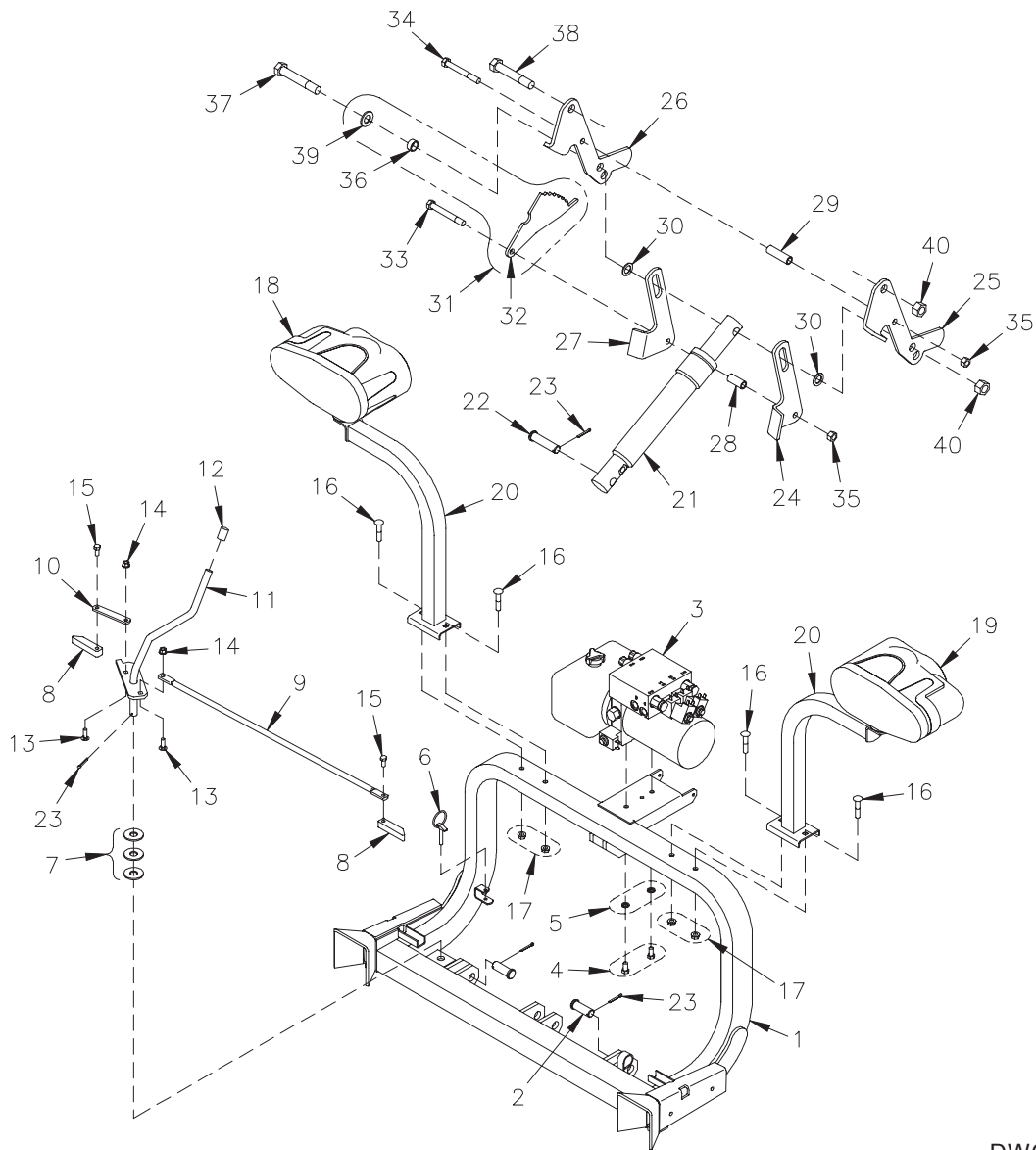

DWG. NO. 6129

REF. NO.	PART NUMBER	DESCRIPTION	QTY.	REF. NO.	PART NUMBER	DESCRIPTION	QTY.
1	25012583	Frame Weldment	1	21	25011402	1 3/4 x 9 Cylinder (See Sec. 2, P. 9)	1
2	953-002-031	Clevis Pin 3/4 x 2	2	22	953-002-032	Clevis Pin 3/4 x 3	1
3	25012648	Power Unit (See Sec. 2, P. 10)	1	23	035-42033	Cotter Pin 5/32 x 1 1/4	4
4	950-001-089	Hex Head Cap Screw 3/8-16 x 3/4 Gr. 5	2	24	25012396	RH Lower Link	1
5	952-001-007	Lock Washer 3/8 Inch	2	25	25012394	RH Upper Link	1
6	703-00209	Klik Pin	1	26	25012393	LH Upper Link	1
7	952-002-007	Flat Washer 5/8 Inch	3	27	25012395	LH Lower Link	1
8	25010276	Slider	2	28	25010114	Lower Link Spacer	1
9	25010274	Long Tie Rod	1	29	25010211	Upper Link Spacer	1
10	25010275	Short Tie Rod	1	30	952-004-003	Machinery Bushing 25/32 x 1 1/4 x .075	2
11	25010410	Handle Weldment	1	31	25011986	Stop Plate Kit (Includes Lock Nut #40)	1
12	25011230	Vinyl Cap	1	32	25011984	Stop Plate	1
13	030-16042	Carriage Bolt 5/16-18 x 1 Gr. 5	2	33	950-001-309	Hex Head Cap Screw 1/2-13 x 4 Gr. 5, 7/8 Thrd Lgth	1
14	951-005-036	Lock Nut 5/16-18 Mac Lock	2	34	950-001-124	Hex Head Cap Screw 1/2-13 x 4 Gr. 5	1
15	950-011-042	Hex Head Cap Screw 5/16-18 x 3/4 Nylon Dri-Lock	2	35	10304	Lock Nut 1/2-13 2-Way	2
16	950-003-070	Carriage Bolt 3/8-16 x 2 Gr. 5	4	36	25011885	Bushing	1
17	951-005-003	Lock Nut 3/8-16 Mac Lock	4	37	950-001-311	Hex Head Cap Screw 3/4-10 x 4 1/2 Gr. 5, 1 1/4 Thrd Lgth	1
18	25012793	LH Headlight Assembly (See Sec. 2, P. 15)	1	38	950-001-310	Hex Head Cap Screw 3/4-10 x 4 1/4 Gr. 5, 1 1/4 Thrd Lgth	1
19	25012792	RH Headlight Assembly (See Sec. 2, P. 15)	1	39	033-12013	Flat Washer 3/4 Inch SAE	1
20	25011334	Light Bracket Weldment	2	40	951-005-037	Lock Nut 3/4-10 2-Way	2

POWER UNIT COVER ASSEMBLY

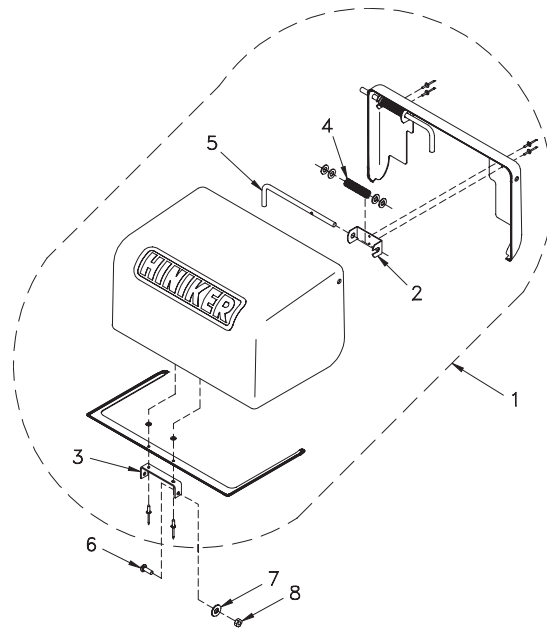

DWG. NO. 5559

REF. NO.	PART NUMBER	DESCRIPTION	QTY.	REF. NO.	PART NUMBER	DESCRIPTION	QTY.
1	25011070	Cover Assembly (Includes Items 2-5)	1	5	25011071	Rod	2
2	25011073	Clevis	2	6	031-10657	Machine Screw 1/4-20 x 3/4 Slotted Round Head	2
3	25011072	Clevis	1	7	952-002-011	Flat Washer 1/4 Inch	2
4	25010717	Compression Spring	2	8	060954	Lock Nut 1/4-20 Nylon Insert	2

1/2" THICK CUTTING EDGES

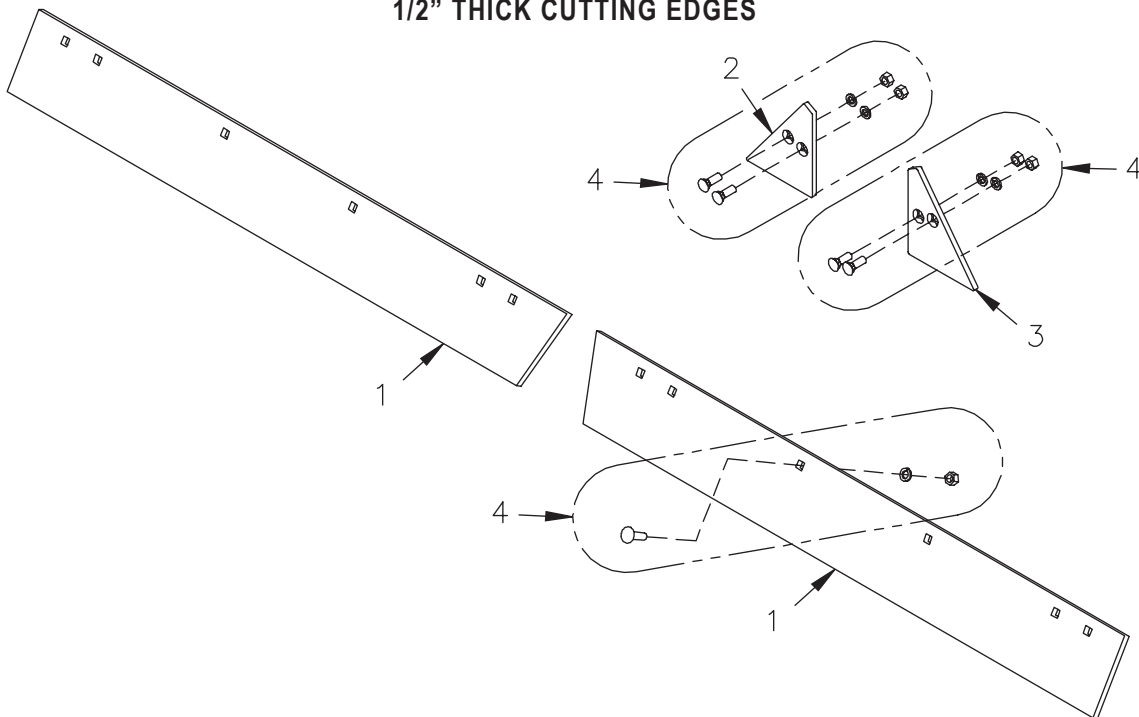

DWG. NO. 6122A

REF. NO.	PART NUMBER	DESCRIPTION	QTY.	REF. NO.	PART NUMBER	DESCRIPTION	QTY.
1	25012420	1/2" Cutting Edge, 8 1/2' Plow	2	3	25012311	LH Center Cutting Edge Plate	1
2	25012421	1/2" Cutting Edge, 9 1/2' Plow	2	4	25012296	Cutting Edge Bolt Kit	1
2	25012310	RH Center Cutting Edge Plate	1				

RUBBER SNOW DEFLECTOR KITS

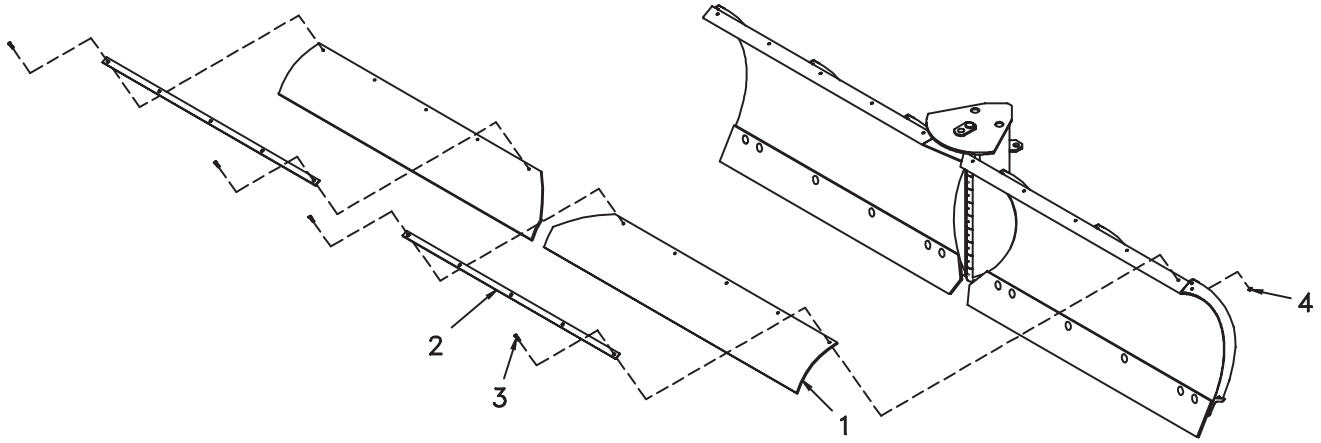

25010633 Snow Deflector Kit For 8 1/2' V-Plow  
 25010910 Snow Deflector Kit For 9 1/2' V-Plow

DWG. NO. 3684A

REF. NO.	PART NUMBER	DESCRIPTION	QTY.	REF. NO.	PART NUMBER	DESCRIPTION	QTY.
1	25010695	Snow Deflector, 8 1/2' V-Plow	2	3	030-16042	Carriage Bolt 5/16-18 x 1" Gr. 5, 8 1/2' V-Plow	10
	25010912	Snow Deflector, 9 1/2' V-Plow	2			Carriage Bolt 5/16-18 x 1" Gr. 5, 9 1/2' V-Plow	12
2	25010690	Snow Deflector Strap, 8 1/2' V-Plow	2	4	951-005-036	Lock Nut 5/16-18 Mac Lock, 8 1/2' V-Plow	10
	25010911	Snow Deflector Strap, 9 1/2' V-Plow	2			Lock Nut 5/16-18 Mac Lock, 9 1/2' V-Plow	12

POLY SNOW DEFLECTOR KITS

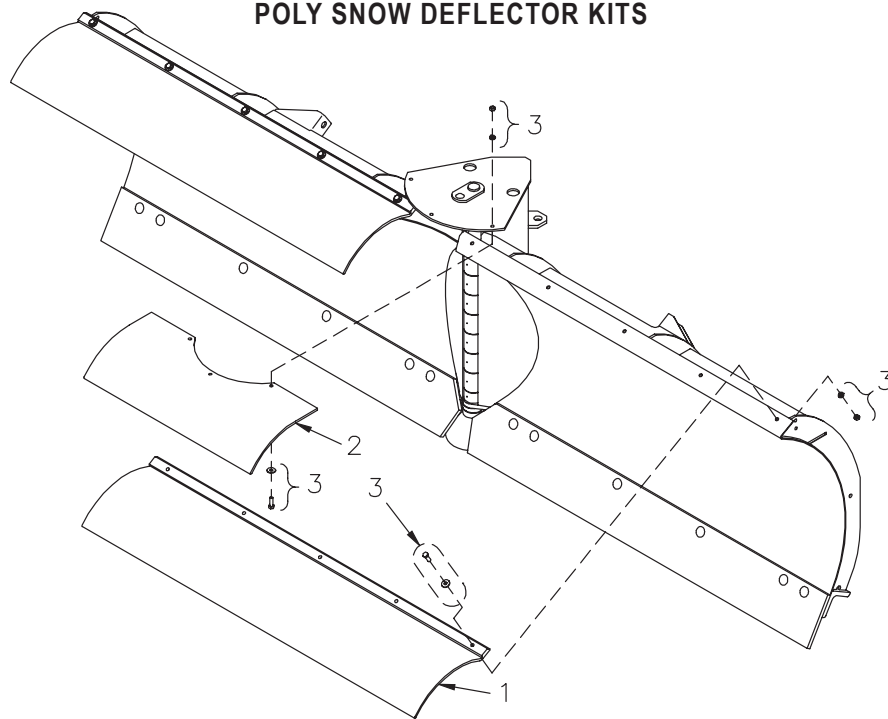

25011791 Poly Snow Deflector Kit For 8 1/2' V-Plow  
 25011792 Poly Snow Deflector Kit For 9 1/2' V-Plow

DWG. NO. 5679

REF. NO.	PART NUMBER	DESCRIPTION	QTY.	REF. NO.	PART NUMBER	DESCRIPTION	QTY.
1	25011794	8' Snow Deflector Extrusion (Cut Into Two Lengths)	1	2	25011796	Center Deflector	1
	25011982	4 1/2' Snow Deflector Extrusion	2	3	25011793	Bolt Box Snow Deflector	1

**WEAR PLATE KIT**

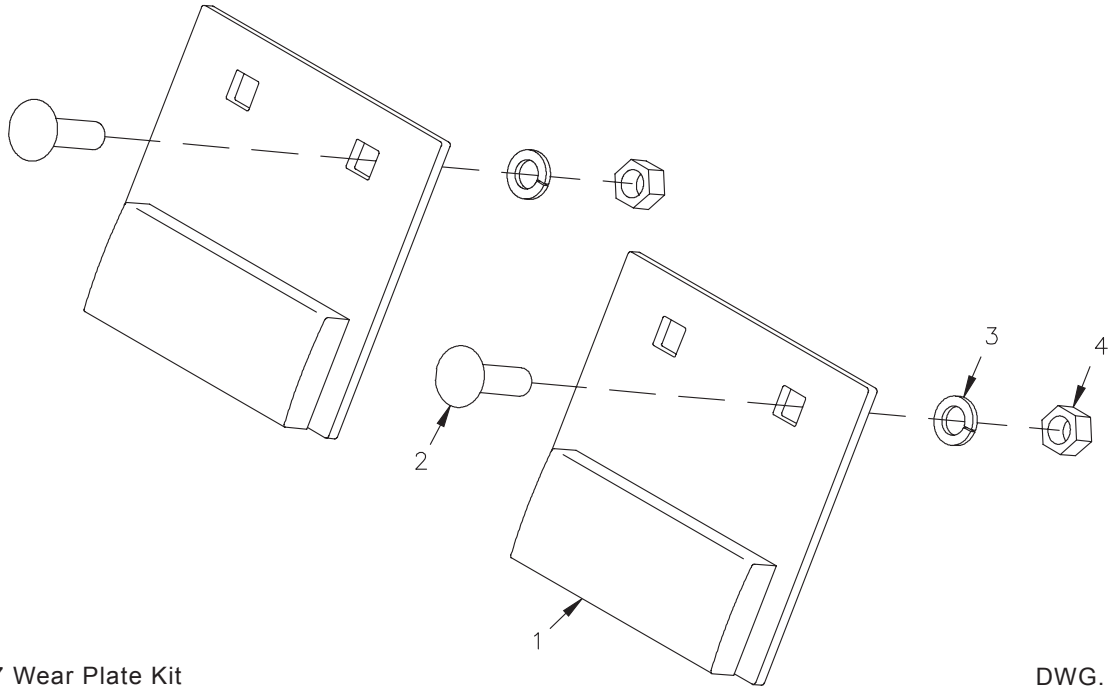

25012587 Wear Plate Kit

DWG. NO. 6331

REF. NO.	PART NUMBER	DESCRIPTION	QTY.	REF. NO.	PART NUMBER	DESCRIPTION	QTY.
1	25012588	Wear Plate Weldment	2	3	952-001-004	Lock Washer 1/2 Inch	4
2	950-003-058	Carriage Bolt 1/2-13 x 1 3/4 Gr. 5	4	4	951-001-007	Hex Nut 1/2-13	4

**CURB GUARD KITS**

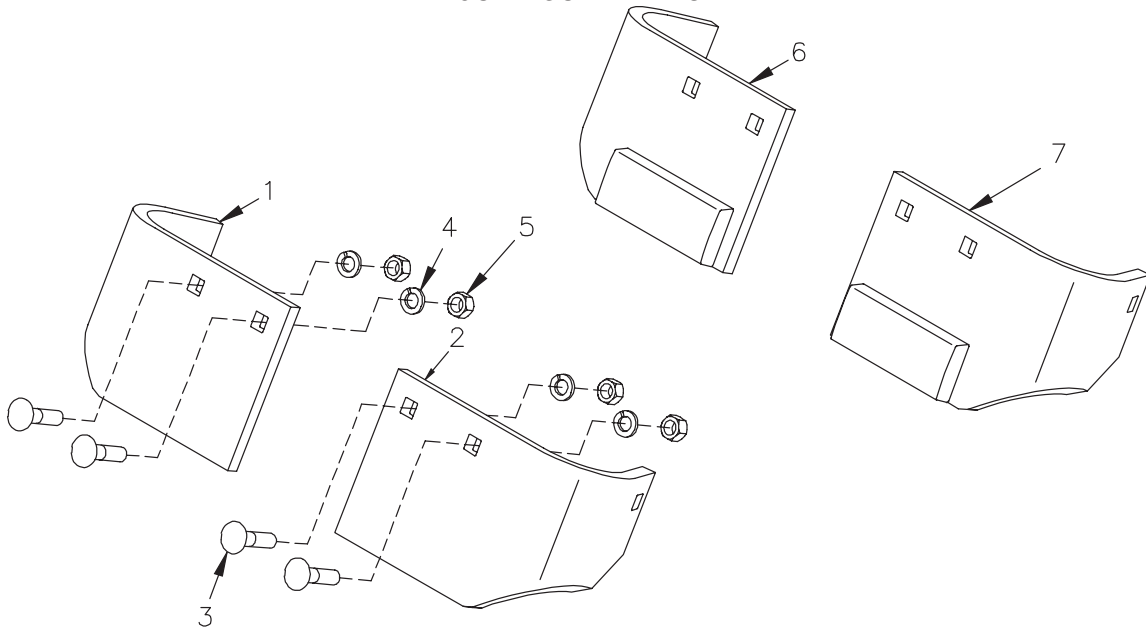

25011695 Curb Guard Kit - Standard  
25012726 Curb Guard Kit With Wear Bars

DWG. NO. 5486

REF. NO.	PART NUMBER	DESCRIPTION	QTY.	REF. NO.	PART NUMBER	DESCRIPTION	QTY.
1	25011712	RH Curb Guard - Standard	1	5	951-001-007	Hex Nut 1/2-13	4
2	25011713	LH Curb Guard - Standard	1	6	25012722	RH Curb Guard With Wear Bar	1
3	950-003-025	Carriage Bolt 1/2-13 x 2 Gr. 5	4	7	25012723	LH Curb Guard With Wear Bar	1
4	952-001-004	Lock Washer 1/2 Inch	4				



HYDRAULIC OVERVIEW

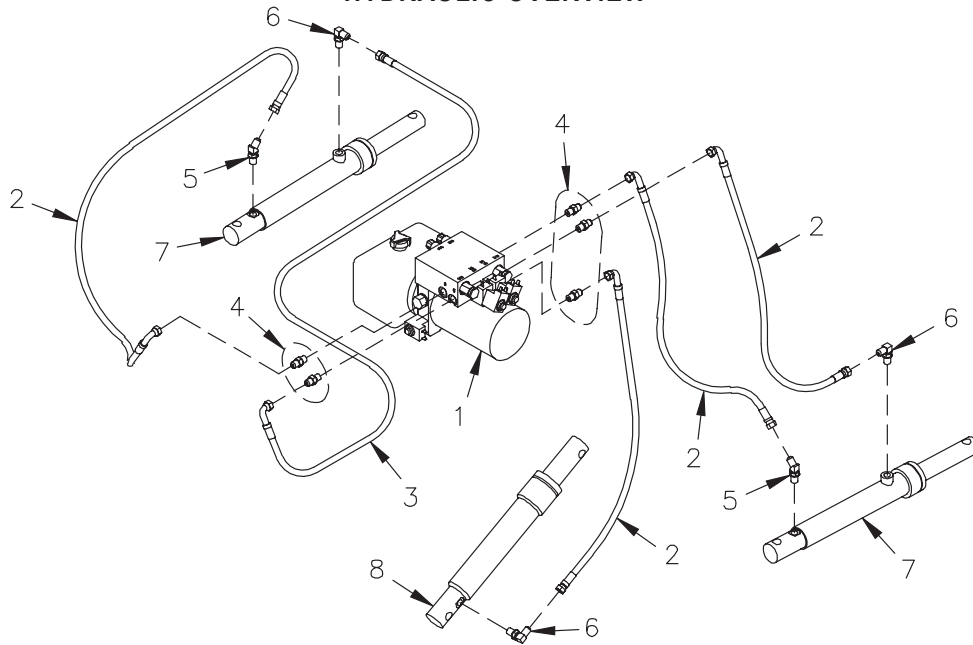

DWG. NO. 6130

REF. NO.	PART NUMBER	DESCRIPTION	QTY.	REF. NO.	PART NUMBER	DESCRIPTION	QTY.
1	25012648	Power Unit (See Sec. 2, P. 10)	1	5	956-005-023	45° Adapter 9/16 ORB x 9/16 JIC	2
2	957-021-002	Hydraulic Hose 1/4 x 33	4	6	956-005-022	90° Adapter 9/16 ORB x 9/16 JIC	3
3	957-021-001	Hydraulic Hose 1/4 x 54	1	7	25012046	1 3/4 x 10 Double-Acting Cylinder (See Sec. 2, P. 12)	2
4	206-01024	Straight Adapter 9/16 ORB x 9/16 JIC	5	8	25011402	1 3/4 x 9 Cylinder (See Sec. 2, P. 9)	1

1 3/4 X 9 LIFT CYLINDER

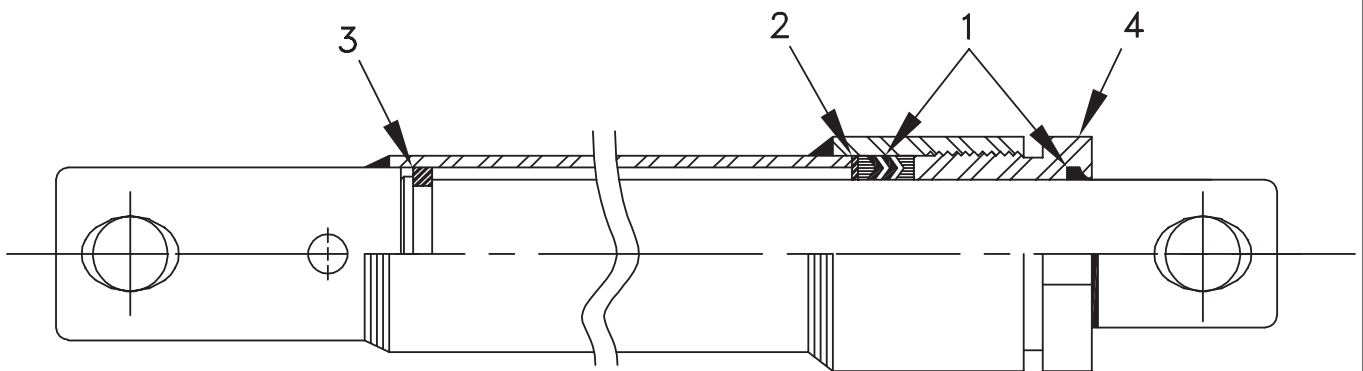

25011402 1 3/4 x 9 Cylinder

DWG. NO. 6141

REF. NO.	PART NUMBER	DESCRIPTION	QTY.	REF. NO.	PART NUMBER	DESCRIPTION	QTY.
1	25010711	Seal Kit - 1 3/4" Rod	1	3	25010707	Guide Ring - 1 3/4" Rod	1
2	25010706	Seat Ring - 1 3/4" Rod	1	4	25010708	Packing Nut - 1 3/4" Rod	1

POWER UNIT - SPX MODEL DB-5245-1

SECTION 2

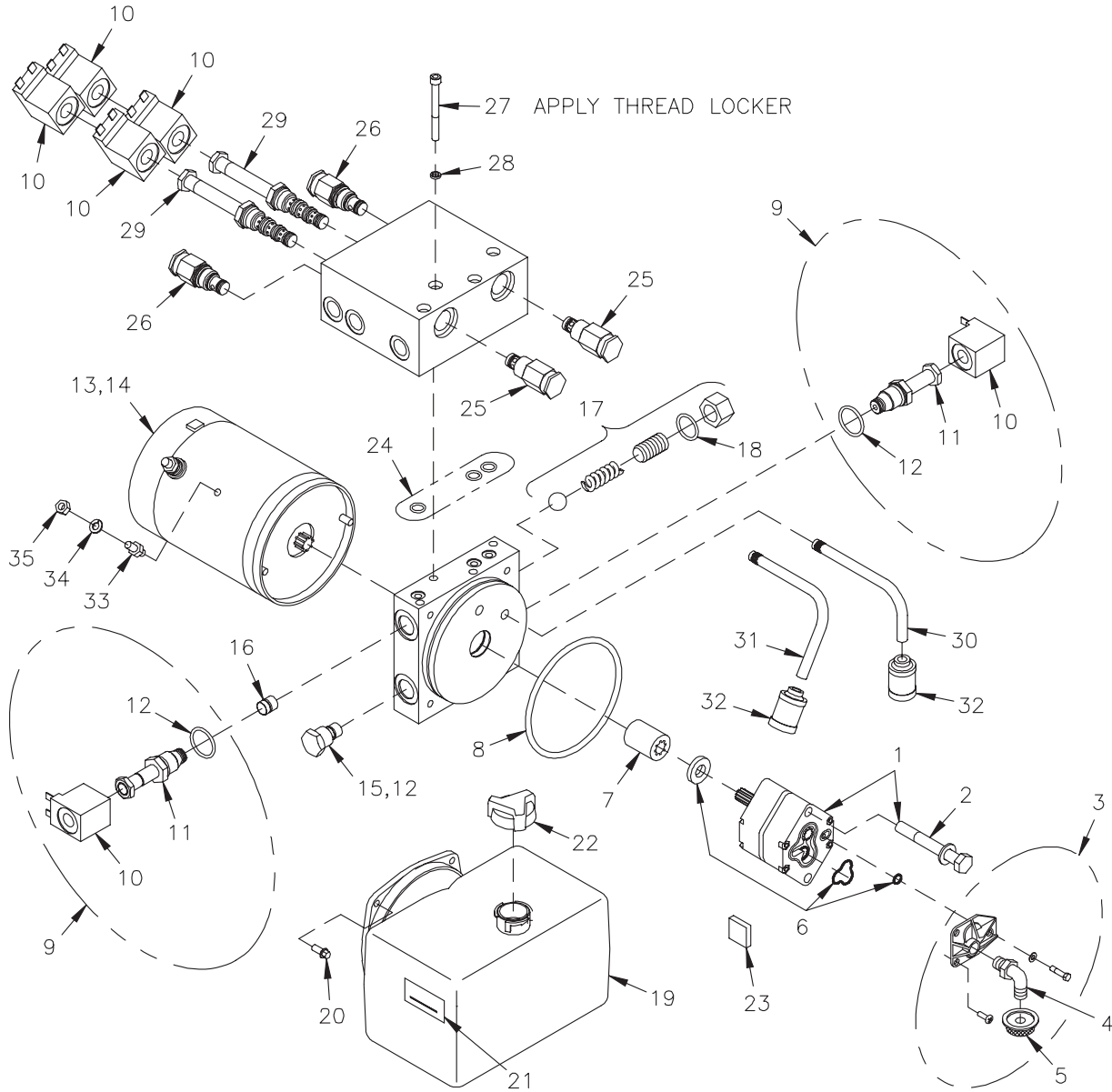

25012648 Power Unit - SPX Model DB-5245-1

DWG. NO. 6526A

REF. NO.	PART NUMBER	DESCRIPTION	QTY.	REF. NO.	PART NUMBER	DESCRIPTION	QTY.
1	25010734	Pump Assembly	1	19	25010738	Plastic Tank	1
2	950-001-327	Hex Head Cap Screw 5/16-24 x 3 Gr. 8	2	20	950-004-071	Machine Screw #12-24 x 1/2 Hex Washer Head	4
3	25010332	Inlet Plumbing Kit	1	21	25010436	Decal - Fill Line	1
4	25010244	Plumbing Elbow	1	22	25010217	Plastic Breather	1
5	25010221	Filter	1	23	25010220	Plumbing Magnet	1
6	25010334	Pump O-Ring Kit	1	24	25010762	Manifold O-Ring Kit	1
7	25010214	Coupling	1	25	25012678	Relief Valve	2
8	25010236	O-Ring	1	26	25010985	Crossover Relief Valve	2
9	25011654	Release Valve Kit	2	27	950-004-095	Socket Head Cap Screw 1/4-20 x 2 1/2	4
10	25011667	Solenoid Coil	6	28	952-004-080	Lock Washer 1/4 Inch	4
11	25010544	Cartridge Release Valve	2	29	25011525	Spool Valve	2
12	25010992	O-Ring Kit	1	30	25010935	Return Tube	1
13	25010230	Motor 12V DC	1	31	25012737	Return Tube	1
14	25010337	Motor Brush Kit	1	32	25010745	Return Tube Filter	2
15	25010746	Check Valve	1	33	25012673	Ground Stud 1/4-20	1
16	25012736	Orifice With O-Ring	1	34	952-001-001	Lock Washer 1/4 Inch	1
17	25010330	Adjustable Relief Valve Kit	1	35	951-001-003	Hex Nut 1/4-20	1
18	25010518	Adjustable Relief Valve O-Ring	1				

POWER UNIT - MTE MODEL S203T-5051

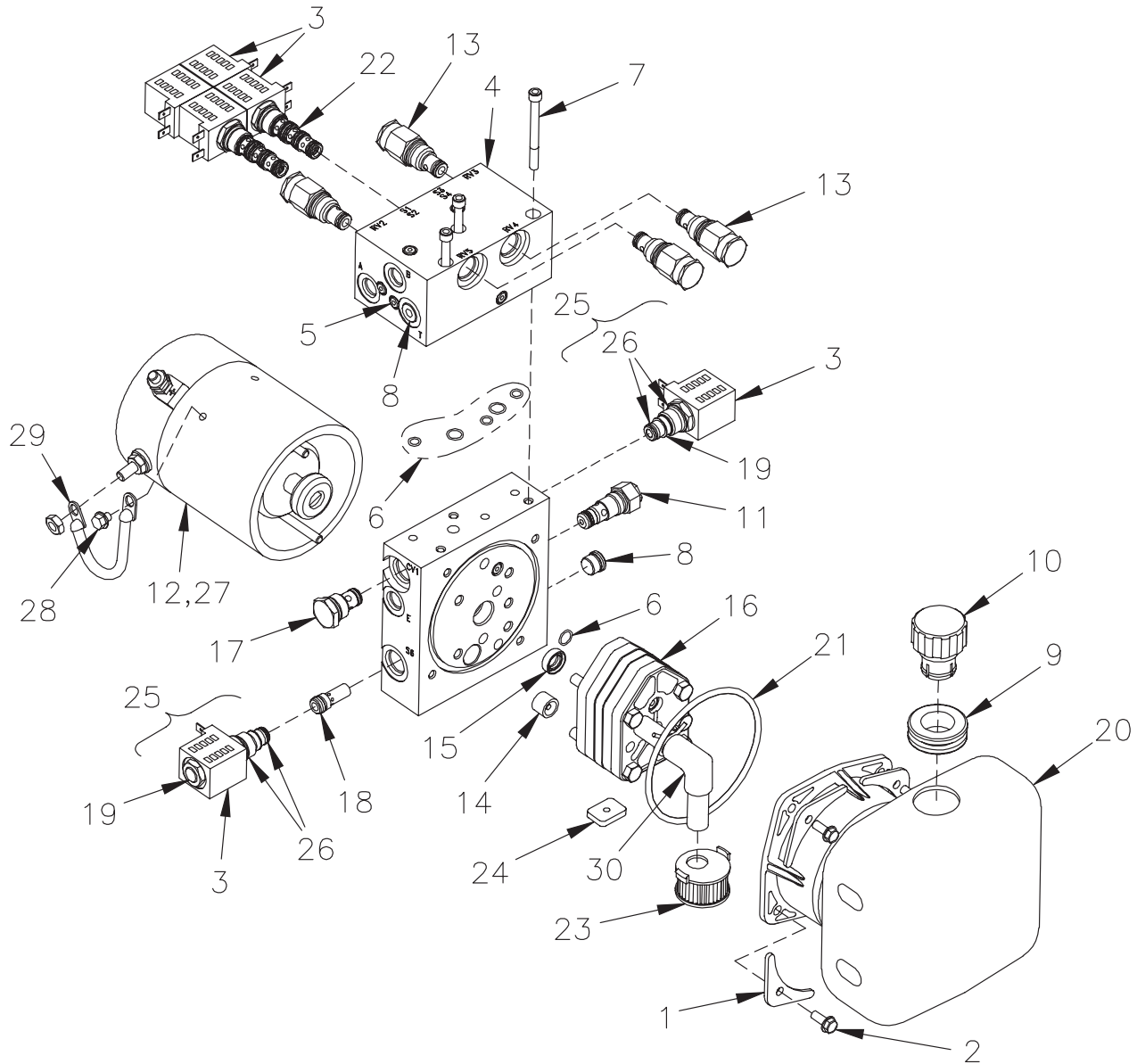

25012080 Power Unit - MTE Model S203T-5051

DWG. NO. 5866

REF. NO.	PART NUMBER	DESCRIPTION	QTY.	REF. NO.	PART NUMBER	DESCRIPTION	QTY.
1	25012154	Clamp, Tank Mounting	4	16	25012231	Pump (Without Milled Undercut For Filter)	1
2	950-004-104	Machine Screw 1/4-20 x 3/4 H WHD	4	17	25012164	Pump (With Milled Undercut For Longer Filter)	1
3	25011667	Coil Assembly 16W 10V	6	18	25012165	Check Valve	1
4	25012155	Manifold V-Plow	1	19	25012166	Flow Control, 2.5 GPM	1
5	25012156	Zero-Leak Plug, 5/16-24	14	20	25010544	Cartridge Valve	2
6	25012170	O-Ring Seal Kit	1	21	25012167	Tank 2.5 Quart	1
7	950-004-095	Socket Head Cap Screw 1/4-20 x 2 1/2	3	22	25012168	O-Ring, Reservoir	1
8	25012157	Zero-Leak Plug, 9/16-18	2	23	25011525	Spool Valve	2
9	25012158	Grommet	1	24	25012169	Filter, Round Plastic	1
10	25012159	Breather	1	25	25010220	Plumbing Magnet	1
11	25012160	Relief Valve	1	26	25011654	Release Valve Kit	2
12	25012205	Motor DC 12 Volt 2-Terminal	1	27	25010992	O-Ring Kit	1
13	25010985	Crossover Relief Valve	4	28	25012173	Motor Brush Kit	1
14	25012232	Bronze Filter 1/2" Long (Used With 25012231 Pump Without Milled Undercut)	1	29	950-004-072	Machine Screw 1/4-20 x 1/4 Hex WHD (Only Required On Motors With Ceramic Washer Under (-) Terminal)	1
	25012162	Bronze Filter 3/4" Long (Used With 25012164 Pump With Milled Undercut)	1	30	38813082	Ground Wire (Only Required On Motors With Ceramic Washer Under (-) Terminal)	1
15	25012163	Oil Seal, Pump	1		25012631	Elbow	1

POLY V-PLOW 9850-9950

1 3/4 X 10 ANGLE CYLINDER

SEC 2

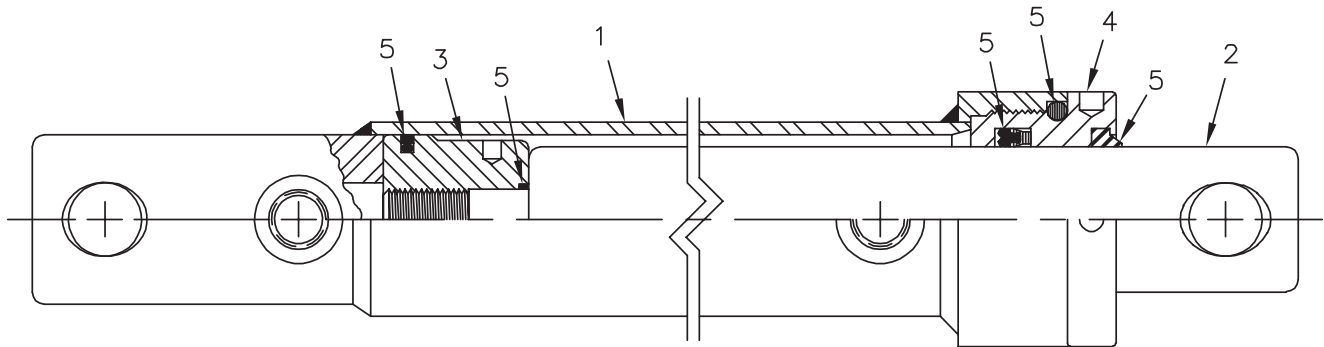

25012046 1 3/4 x 10 Cylinder

DWG. NO. 5878

REF. NO.	PART NUMBER	DESCRIPTION	QTY.	REF. NO.	PART NUMBER	DESCRIPTION	QTY.
1	25012055	Body Assembly	1	4	25012052	Rod Gland	1
2	25012054	Rod	1	5	25012088	Seal Kit	1
3	25012053	Piston	1				

JOYSTICK CONTROLLER

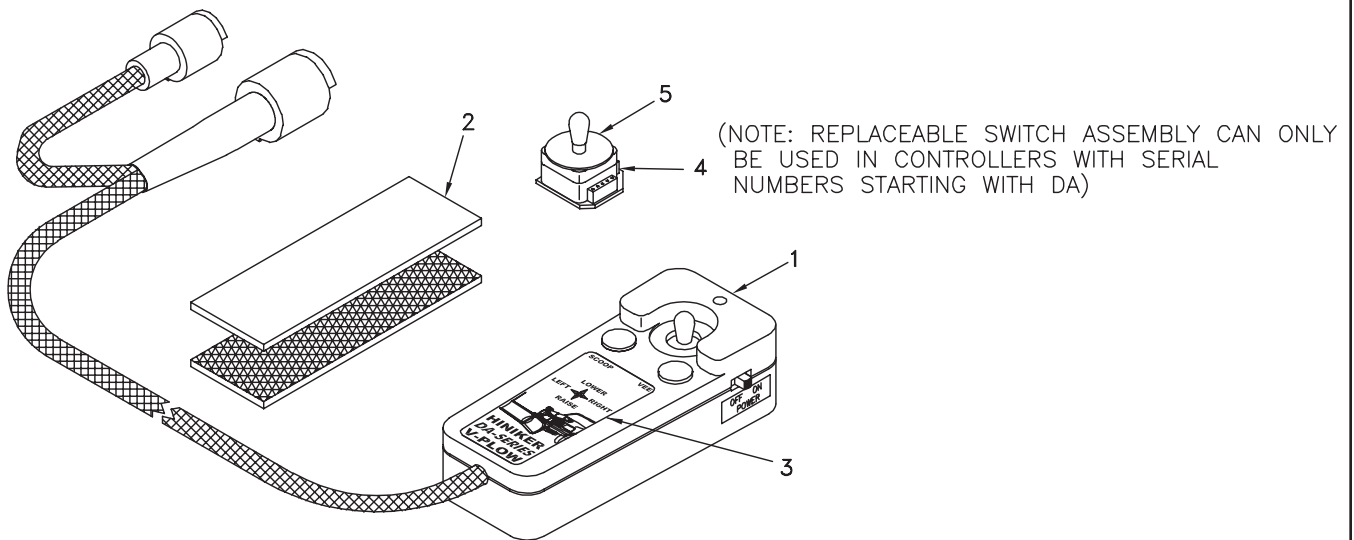

DWG. NO. 5928

REF. NO.	PART NUMBER	DESCRIPTION	QTY.	REF. NO.	PART NUMBER	DESCRIPTION	QTY.
1	36014026	Controller DA V-Plow	1	4	36014019	Switch Assembly	1
2	39108005	Hook & Loop Assembly	1	5	36716033	Gasket, Neoprene	1
3	39302153	Decal DA Joystick Top 2 Sided	1				

UNDERHOOD WIRING HARNESS

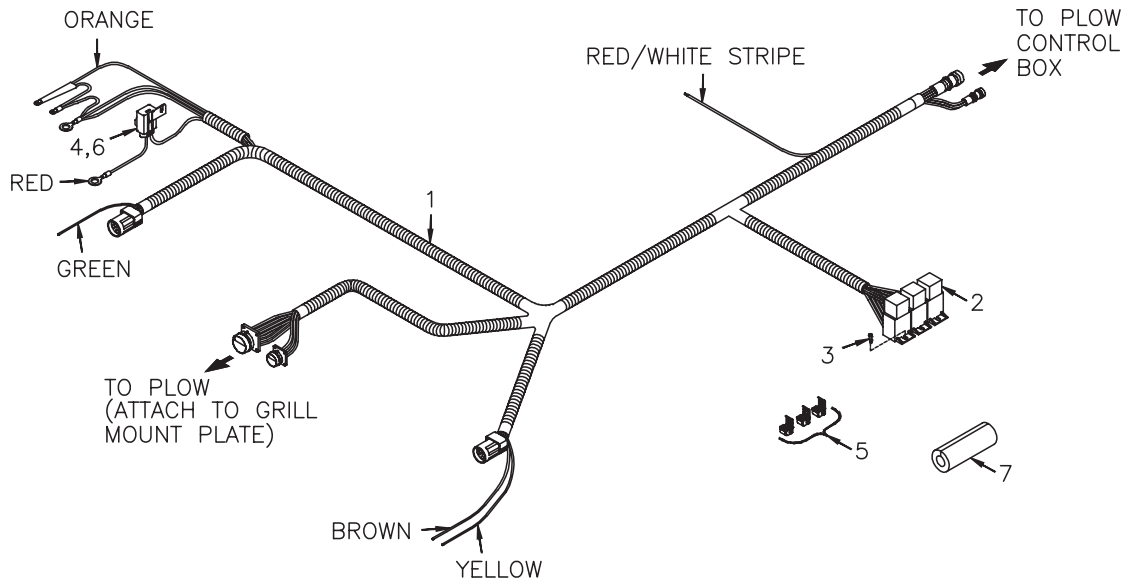

DWG. NO. 3943A

REF. NO.	PART NUMBER	DESCRIPTION	QTY.	REF. NO.	PART NUMBER	DESCRIPTION	QTY.
1	38813033	Harness, 6 Function Underhood (Includes Relays And Fuse)	1	4	39207031	10 Amp Fuse	1
2	38350010	Headlight/Accessory Relay	3	5	38610104	Sealed Quick Connect	3
3	031-30078	S-Tap Screw #8-18 x 1/2 Slotted Hex Head	3	6	38400012	Cover, Fuse Holder	1
				7	39107001	Foam Grommet 4" Long	1

MOTOR SOLENOID

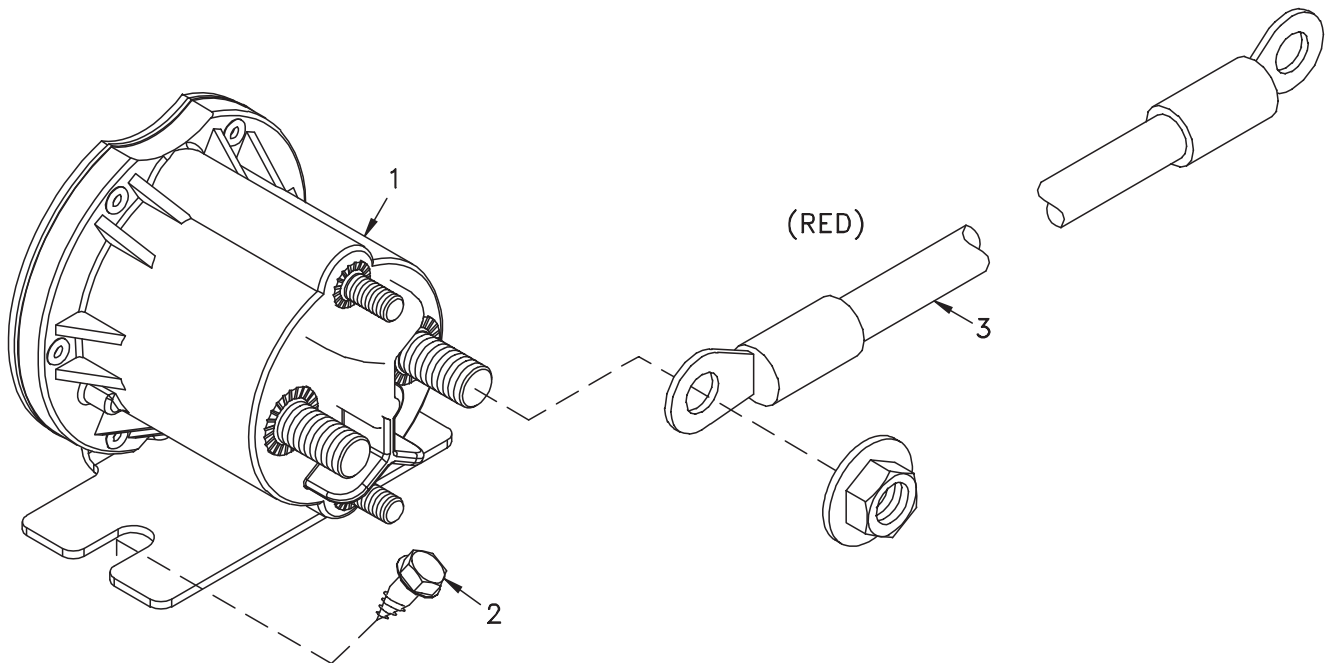

DWG. NO. 6559

REF. NO.	PART NUMBER	DESCRIPTION	QTY.	REF. NO.	PART NUMBER	DESCRIPTION	QTY.
1	38350015	Motor Solenoid, Sealed	1	3	38813012	Solenoid Cable, Red	1
2	950-005-004	Self Tapping Screw 1/4-20 x 1/2 Hex Washer Head	2				

**POWER CABLES**

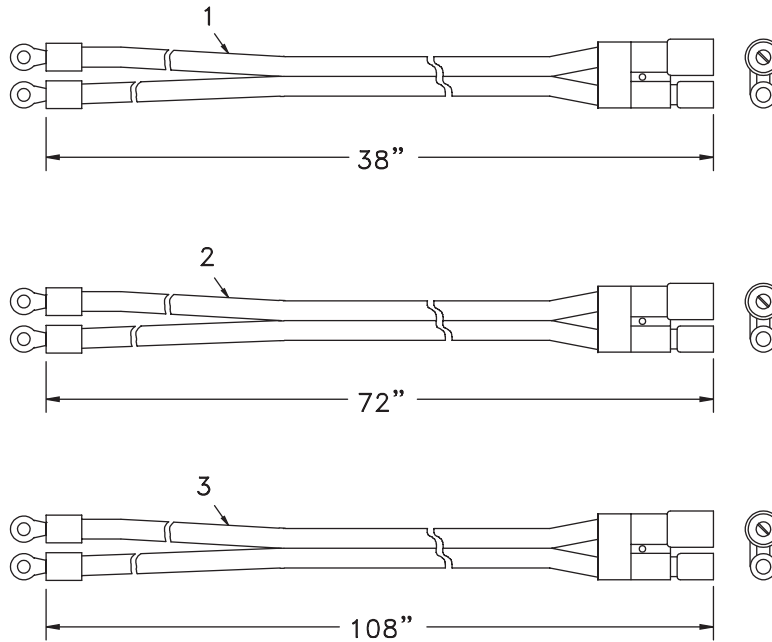

DWG. NO. 5342

REF. NO.	PART NUMBER	DESCRIPTION	QTY.	REF. NO.	PART NUMBER	DESCRIPTION	QTY.
1	38812008	Battery Power Cable - Snow Plow	1	3	38813066	Battery Power Cable - Truck 9 Ft.	1
2	38813007	Battery Power Cable - Truck 6 Ft.	1				

**PLOW WIRING HARNESS**

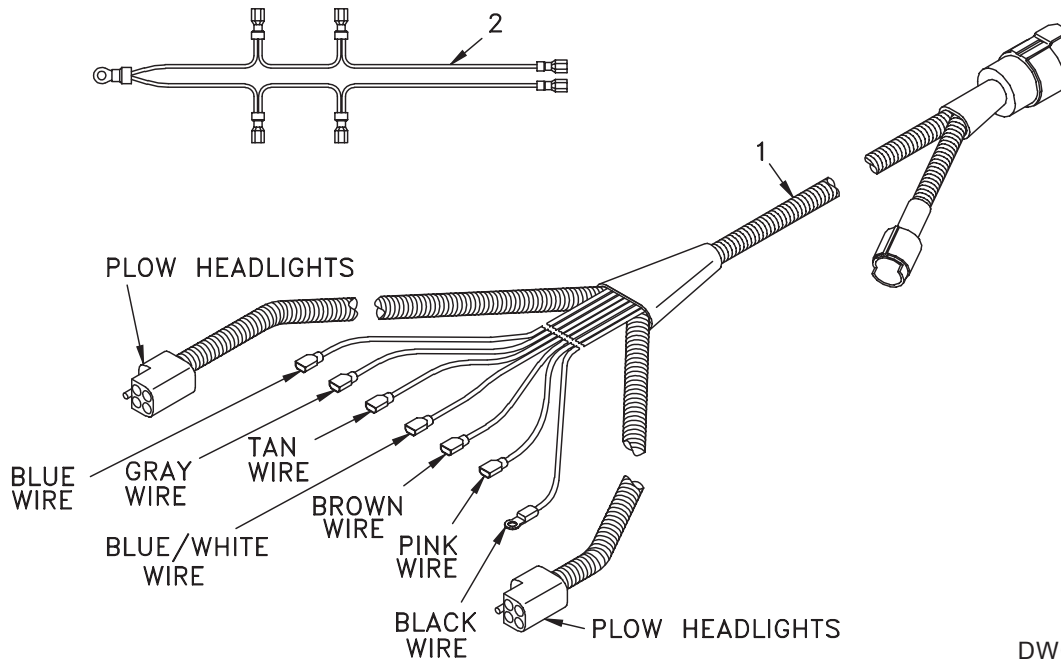

DWG. NO. 5228

REF. NO.	PART NUMBER	DESCRIPTION	QTY.	REF. NO.	PART NUMBER	DESCRIPTION	QTY.
1	38813035	6 Function External Cable Assembly	1	2	38813096	Ground Harness With 1/4" Ring (Use With Power Unit DB-5245-1)	1
					38813070	Ground Harness With 5/16" Ring (Use With Power Unit 81002224)	

HEADLAMPS

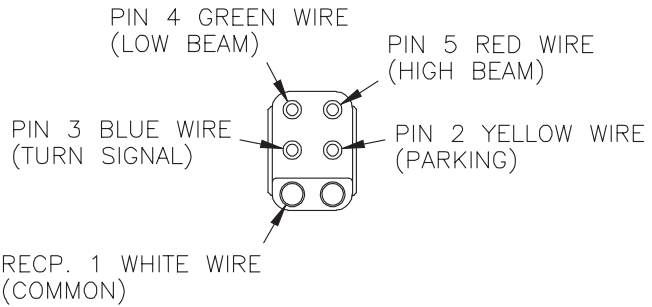
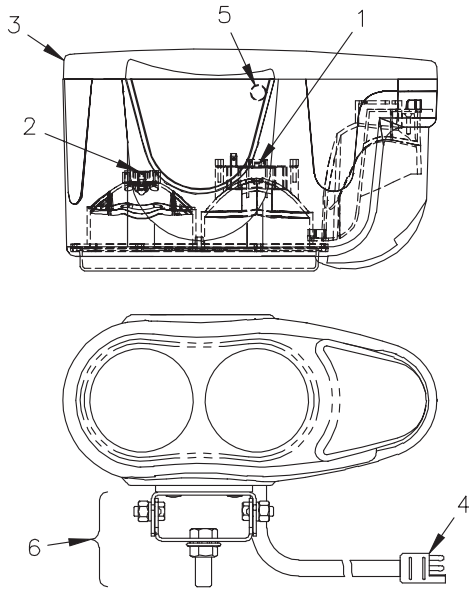

DWG. NO. 6628

REF. NO.	PART NUMBER	DESCRIPTION	QTY.	REF. NO.	PART NUMBER	DESCRIPTION	QTY.
	25012793	LH Light Assembly	1	5	25012417	Conduit Clamp	1
	25012792	RH Light Assembly	1	6	25012794	Mounting Hardware Kit	1
1	25012416	Spring Clip, High Beam	1		N/A	High Beam Headlight Bulb - One #H1 12V, 55W	1
2	25012415	Spring Clip, Low Beam	1		N/A	Low Beam Headlight Bulb - One #H7 12V, 55W	1
3	25012414	Back Panel, LH Light	1		N/A	Turn Signal/Parking Bulb - One #1157 Heavy Duty Double Contact 32/3 C.P.	1
	25012419	Back Panel, RH Light	1				
4	25012418	Wire Harness	1				

GRILL MOUNT PLATE

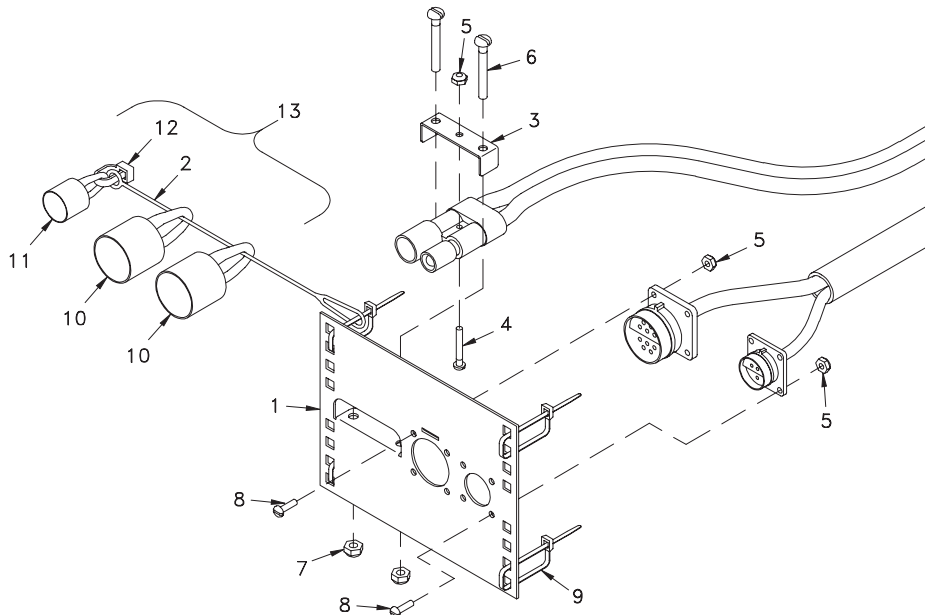

DWG. NO. 6332

REF. NO.	PART NUMBER	DESCRIPTION	QTY.	REF. NO.	PART NUMBER	DESCRIPTION	QTY.
	25010783	Complete Mount Plate Kit Items 1-13	1	7	392-010-010	Lock Nut #10-24 Nylon Insert	2
1	36507004	Plug Mount Plate	1	8	950-004-033	Machine Screw #6-32 x 1/2 Slotted Pan Head	8
2	36716025	Nylon Lanyard 8"	1	9	367-001-011	Plastic Tie, 14"	4
3	25011037	Clamp	1	10	36716002	Large Dust Cap	2
4	700-10904	Machine Screw #6-32 x 1" Slotted Pan Head	1	11	36716034	Small Dust Cap	1
5	951-003-014	Lock Nut #6-32 Nylon Insert	9	12	367-001-014	Cable Tie, 8 In.	1
6	950-004-076	Machine Screw #10-24 x 1 1/2 Slotted Pan Head	2	13	36014018	Dust Cap Assembly	1

