



SKID STEER LOADER SNOWPLOW

STEEL STRAIGHT PLOW

MODELS 2275, 2280, 2285

SCOOP PLOW

MODELS 2682, 2692

10' TRIP EDGE STRAIGHT PLOW

MODEL 2103

OPERATOR'S MANUAL

DO NOT USE OR OPERATE THIS EQUIPMENT UNTIL THIS MANUAL
HAS BEEN READ AND THOROUGHLY UNDERSTOOD

PART NUMBER 25013756 Rev. A

TABLE OF CONTENTS

25013756 Rev. A

4/17

MANUALS/25013756RevA

TO THE PURCHASER.....	2
SAFETY.....	3
OPERATING PROCEDURES	4
MAINTENANCE	6
TROUBLE SHOOTING	7
STEEL STRAIGHT PLOW ASSEMBLY.....	8
SCOOP/10' STRAIGHT PLOW ASSEMBLY	9
HYDRAULIC RELIEF VALVE DIAGRAM	10
SPECIFICATIONS.....	11
WARRANTY	12

TO THE PURCHASER

This product is designed and manufactured to give years of dependable service when properly maintained and used for the purpose for which it is intended. Never allow anyone to operate this equipment until they fully understand the complete contents of this manual. It is the responsibility of owners who do not operate this equipment to ensure the operator is properly instructed and understands the contents of this manual. It is also the owner's responsibility to ensure that anyone operating this equipment is mentally and physically capable of so doing.

Important information is contained in this manual to help ensure safe and efficient operation.

If you have any questions about this manual, or the equipment discussed herein, contact your snowplow dealer



TAKE NOTE! THIS SAFETY ALERT SYMBOL FOUND THROUGHOUT THIS MANUAL IS USED TO CALL YOUR ATTENTION TO INSTRUCTIONS INVOLVING YOUR PERSONAL SAFETY AND THE SAFETY OF OTHERS. FAILURE TO FOLLOW THESE INSTRUCTIONS CAN RESULT IN INJURY OR DEATH.



THIS SYMBOL MEANS:

- ATTENTION!
- BECOME ALERT!
- YOUR SAFETY IS INVOLVED!



SAFETY SIGNAL WORDS:

DANGER: Indicates an imminently hazardous situation that, if not avoided, will result in death or serious injury.

WARNING: Indicates a potentially hazardous situation that, if not avoided, could result in death or serious injury.

CAUTION: Indicates a potentially hazardous situation that, if not avoided, may result in minor or moderate injury, or damage to components.

NOTE: Addresses safety practices not related to personal safety.

All references to Left or Right are defined as viewing the plow from the cab of the machine.

This Operator's Manual is shipped with this equipment. Contact your dealer for additional copies.

Always obtain original Hiniker service parts. Substitute parts could adversely affect equipment performance and warranty.

Check that your dealer has forwarded the delivery report form along with the plow identification number because it helps maintain maximum service and warranty benefits. This does not put you on any mailing list, and information thereon is not available to others.

Your plow's identification number plate is at location (1) in the following illustration.

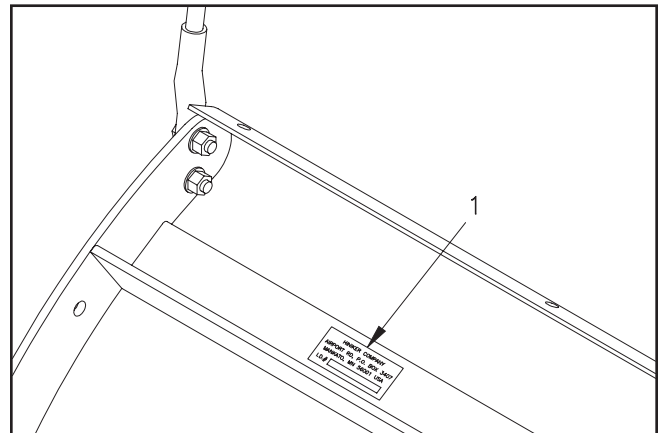

DWG NO. 3199

Record the following information for later reference when obtaining service parts:

Purchase Date _____

Purchaser's Name _____

Dealer's Name _____

Machine I.D. No. _____

SAFETY



This is a safety alert symbol. It alerts an operator to information concerning personal safety. Always observe and heed these symbols and instructions, otherwise death or serious injury can result.

Operator safety is a principle concern in equipment design and distribution. However, many accidents occur because a few seconds of thought, and a more careful approach to handling, were ignored. Accidents can be avoided by knowing and following the precautions cited in this manual.

GENERAL SAFETY

1. Read this manual thoroughly. Make sure the operator understands it and knows how to operate this equipment safely. This equipment can kill or injure an untrained or careless operator and bystanders. If you sell this equipment, ensure the new owner acknowledges receipt of this manual.
2. This manual **Does Not** instruct the operation or maintenance of the skid steer loader. Obtain training on control and function of the skid steer loader from your loader dealer.
3. This plow is intended for plowing snow only. Plowing gravel, rocks, etc., or using the plow for any purpose other than plowing snow could result in harm to the operator or bystanders or cause damage to the plow and will void the warranty.
4. Do not attempt to handle or service this equipment, or direct others to do the same, unless you know how to do it safely and have the proper tools for the job.
5. Do not service or otherwise handle a plow in the raised position unless it is securely blocked against unexpected falling.
6. Keep hands, feet, hair, and clothing away from moving parts.
7. Do not alter the equipment to the extent of compromising safety or performance.

BEFORE OPERATION

1. Discipline yourself to visually check for worn, damaged or cracked parts before starting use. Replace these with genuine Hiniker service parts.
2. Escaping hydraulic oil under pressure can penetrate the skin, causing serious injury.

Do not use your hand to check for leaks. Use a piece of paper or cardboard to find suspected leaks. Tighten all connections before pressurizing hydraulic lines. If fluid is injected into the skin, get medical attention immediately to prevent serious infection.

3. Check all controls and operating functions of the machine in a safe area before starting to work.

DURING OPERATION

1. Always wear the seat belt and lower the seat bar, if equipped, when operating the loader.
2. Make sure all controls are in the neutral position before starting the loader.
3. Ensure everyone is clear of the machine, especially away from blind areas of the operator, before actuating hydraulics or operating this equipment.
4. Do not plow snow at excessively high speeds.
5. Avoid hitting objects that will damage your plow.
6. Set the brakes and stop the loader's engine before adjusting or servicing your plow.

AFTER OPERATION

1. Park the plow on a solid, level surface.

OPERATING PROCEDURES



IMPORTANT: To prevent damage to snowplow components, skid steer loaders with a “High Flow/Low Flow” hydraulic system must be operated in the Low Flow setting when the plow is attached.

ATTACHING THE PLOW

Mount the plow on the skid steer loader by driving the loader into the mount frame, then set the brakes and relieve hydraulic pressure before exiting the cab. Secure the plow frame to the loader as instructed in the loader manual. Make sure all latches are fully locked in place to prevent the plow from detaching.

Clean quick couplers of dirt before making hydraulic connections. Make sure quick couplers are fully engaged. If quick couplers do not fully engage, check that the couplers are the same size and type. Check also to see that hydraulic pressure has been relieved. See your loader or attachment dealer for coupler information.

Test the lifting and angling functions in a safe area before using the plow.

CONTROLLING THE PLOW FUNCTIONS

Raise and lower the plow by operating the loader arms as you would for any other attachment. Avoid tipping the mount plate forward to apply down pressure on the plow.

Angle the plow left and right by directing oil through the auxiliary hydraulic ports on the skid steer loader. Reverse oil flow to angle the blade the opposite direction.

Release the hydraulic flow controller to hold the blade at an angle position between full left or full right. If the plow angles opposite from what is expected, switch couplers on the two feed hoses that connect to the loader.

TRANSPORTING THE PLOW

Raise the blade to a position where it does not block your view forward. Transport the plow with hydraulic flow off or in neutral to prevent accidental lowering of the plow. Never adjust the blade position while driving.

PLOWING SNOW



WARNING: Always wear the seat belt and lower the seat bar, if equipped, when plowing snow. Sudden contact with a hidden object can result in serious personal injury.

Inspect areas to be plowed before snowfall for potential hazards, and mark obstructions with stakes that will be seen when snow covers the ground. Identify any emergency equipment and utility outlets that may need to be cleared in the event of a storm. Prepare a plan beforehand for clearing snow from tight or enclosed areas and locate sites for stacking snow.

When using skid shoes on the back of the moldboard, adjust the skids according to the surface to be plowed. The bottom of the skids should be about 1/2” below the cutting edge when plowing gravel roads or lots. Skids should be even with the cutting edge on hard surfaces such as asphalt or concrete.

Set the loader lift arms into the float mode so the plow can follow the contour of the ground and clean up low areas while plowing snow.

Always plow snow as it is accumulating. Wet snow may weigh about 12 pounds per cubic foot. The weight of snow being pushed by your plow may increase to several tons.

Allowing snow depth to grow to unmanageable levels can cause difficult removal problems and can be costly in terms of wear on equipment.



WARNING: Serious personal injury can result from plowing at excessive speeds, as well as costly damage to equipment and property, if an obstruction is encountered while plowing. Do not exceed 10 mph while plowing.

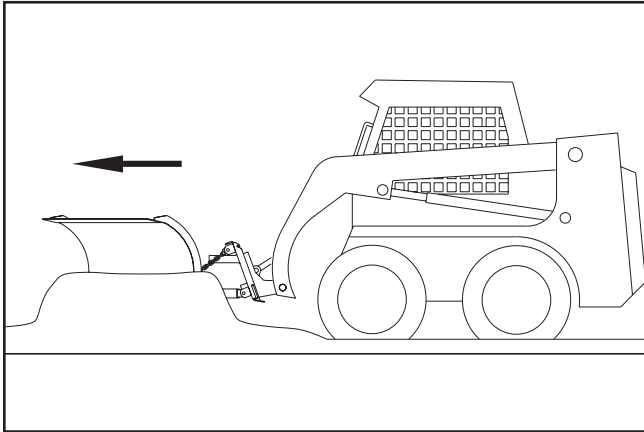

DWG NO. 4244

Clear large lots by angling the blade and creating a single path. Push snow to outer edges of the lot by taking successive passes with the blade angled.

When plowing very deep snow, it may be necessary to raise the blade and shear off layers of snow until a working area is cleared. Work small areas in multiple passes to push snow to outer edges. Generally, 6 inch snow can be plowed with the entire blade width; 9 inch snow with 3/4 of the blade width; 12 inch snow with 1/2 of the blade width. Local conditions will determine how much work can be done before stalling or getting stuck.

REMOVING THE PLOW

Park the plow on a solid level surface with the blade straight across the loader.

Lower the blade to the ground, relieve hydraulic pressure and set the brakes on the loader.

Uncouple the hydraulic feed lines from the loader and unlatch the attachment mechanism at the front of the loader. Slowly drive the loader back away from the plow.

MAINTENANCE



WARNING: Do not service or otherwise handle a plow in the raised position unless it is securely blocked against unexpected falling.

Dependable snowplow operation is the result of following good maintenance procedures. Inspect your plow frequently to ensure that all parts are working smoothly, and develop a schedule for maintenance at required intervals.

GENERAL

Wash salt and dirt off the plow before storage. Do not power wash hydraulic cylinders, as high pressure can damage seals and cause cylinder failure. Touch-up any chips or scratches in the paint and apply a light coating of grease to extended cylinder rods to prevent corrosion.

MECHANICAL COMPONENTS

Prior to the operation of a new snowplow, or one which has been stored, inspect all hardware and verify proper torque on all bolts and nuts in accordance with the recommended torque specifications.

GRADE 5 TYPE B & F LOCK NUT TORQUES

Size	Ft-lbs.	N-m
5/16"	13-18	17-25
3/8"	23-33	31-44
1/2"	58-82	79-112
5/8"	117-165	158-223

GRADE 5 BOLT TORQUES*

Size	Ft-lbs.	N-m
1/4"	8-12	11-16
3/8"	29-41	39-56
1/2"	73-103	99-140
5/8"	146-206	198-279

*applications without lock nuts.

Loose bolts can cause hole elongation and part failure resulting in dangerous operating conditions and equipment breakdown.

Check all hardware periodically during operation and keep tightened to specified torques. Replace worn bolts and lock nuts with grade 5 bolts and equivalent type B or type F lock nuts. Type B lock nuts are plain hex; type F lock nuts are flanged hex.

Inspect wear of the cutting edge before every plowing season and frequently throughout the season. Replace the cutting edge before wear reaches the main plow blade.

Models 2275, 2280, 2285

Once a year before using the plow, check that the moldboard will trip freely about its three hinge pins. With the snowplow mounted on the loader and the cutting edge on the ground, remove the compression springs from the back of the moldboard by loosening the 3/4" lock nuts behind the springs and pull the top of the moldboard fully forward. If the moldboard doesn't pivot freely, remove the three hinge pins one at a time by driving a spring pin out from one end of the hinge pin, and coat each pin with a commercially available anti-seize lubricant. Damage to the snowplow may result if the moldboard hits an obstruction during use and doesn't trip.

Reassemble the compression springs, washers and lock nuts onto the threaded pullrods, and tighten the lock nuts until the springs measure 13 inches long. Do not over tighten compression springs.

TROUBLE SHOOTING

GENERAL

1. Check that hydraulic quick couplers are fully engaged.
2. Check the hydraulic oil level in the skid steer loader.
3. Check for external leakage at cylinders and hoses.

PROBLEM	POSSIBLE CAUSE	REMEDY
1. Hydraulic cylinder does not function or functions slowly when hydraulics are activated.	A. Oil level low. B. Hydraulic connection leak.	A. Add oil (do not overfill). B. Tighten or redo connection.
2. Plow angles opposite expected direction.	A. Feed hoses reversed.	A. Switch quick couplers on feed hoses.
3. Oil leaks from cylinder(s).	A. Loose packing. B. Defective cylinder.	A. Tighten packing 1/8 turn. B. Repack or replace cylinder.
4. Angling cylinders relieve too easily or too difficultly while plowing.	A. Relief pressure set too low or too high.	A. Have relief pressure adjusted by snowplow dealer.
5. Plow does not clean-up snow from low areas.	A. Loader arms not in float mode.	A. Loader arms should be in the float mode.
6. Hydraulic quick couplers don't connect.	A. Wrong size or type of couplers. B. Oil pressure in loader lines.	A. Verify matching couplers. B. Relieve hydraulic pressure in loader.

STEEL STRAIGHT PLOW ASSEMBLY

GENERAL INFORMATION



WARNING: To prevent personal injury or death, be certain to keep clear of any parts that may drop when removing bundling straps, wires or brackets. Support heavy sections with hoist or blocks before removing wires or straps.

PLOW ASSEMBLY

1. Place moldboard face down on cardboard or other padding that will prevent scratches in the paint.

Remove the two 5/8" bolts through the center ribs on the back of the moldboard, and save for reinstallation later.

Remove the three hinge pins from the back of the moldboard by driving out one spring pin, and save for reinstallation.

Additional compression springs are included with 8 1/2" moldboards. Remove springs and set aside for reassembly.

2. Carefully lift the frame assembly with a hoist or forklift and move it to the moldboard assembly.

Attach the frame assembly to the moldboard by lining up the three bushings on the frame with the three sets of bushings on the moldboard.

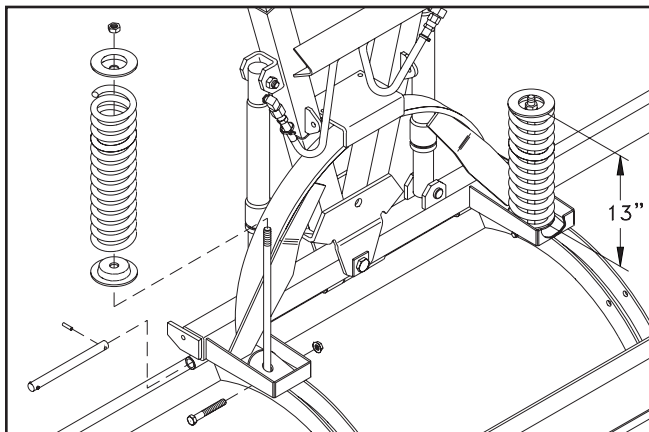

DWG NO. 5150

Apply a commercially available anti-seize lubricant (not supplied) to the hinge pins to prevent future corrosion, and reinstall the hinge pins

through the bushings. Secure the hinge pins with spring pins.

Remove 3/4" lock nuts from the back of each compression spring. Align each pullrod bushing with the upper set of holes in the moldboard ribs and reinstall 5/8" bolts and lock nuts. Tighten lock nuts only until snug against ribs.

Assemble 3/4" lock nuts back onto pullrods and tighten until compression springs measure 13" long. Do not overtighten springs.

If assembling an 8 1/2' plow, remove endcaps from compression springs and install an extra spring inside each existing spring. Place endcaps on springs and tighten 3/4" lock nuts on pullrods until the outer springs measure 13" long. Do not overtighten springs.

3. Assemble side markers to the ends of the moldboard with 5/16 inch hex bolts, flat washers and lock nuts.

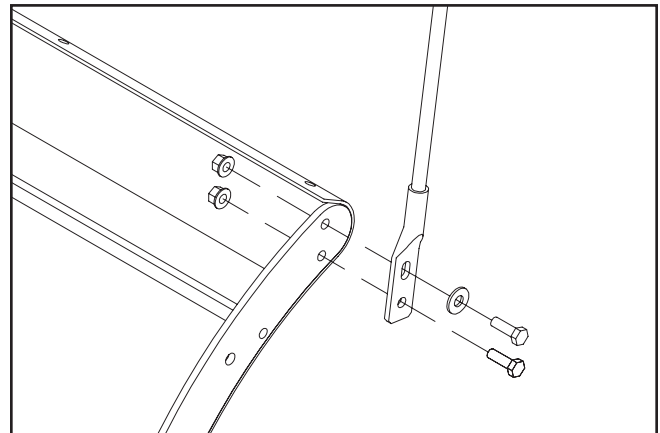

DWG NO. 7215

4. Refer to operating procedures section for attaching the plow to the loader and operating the plow. Test the plow functions in a safe area.

QUICK COUPLERS

Select and install hydraulic quick couplers and adapter fittings on the snowplow feed lines according to the size and type (i.e. flat face or poppet style) of couplers on the skid steer loader.

Hoses supplied on the snowplow have 9/16-18 JIC female swivel ends for 9/16-18 JIC male adapters.

SCOOP/10' STRAIGHT PLOW ASSEMBLY

GENERAL INFORMATION



WARNING: To prevent personal injury or death, be certain to keep clear of any parts that may drop when removing bundling straps, wires or brackets. Support heavy sections with hoist or blocks before removing wires or straps.

Be certain that hydraulic hoses and electrical wires are safely routed and allow full motion of moving parts. Secure loose hoses and wires with plastic tie straps.

PLOW ASSEMBLY

1. Place moldboard face down on cardboard or other padding that will prevent scratches in the paint.

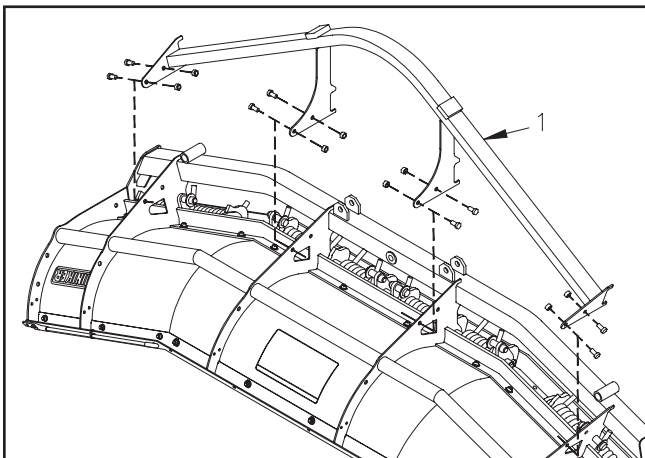

DWG NO. 7345A

Unbolt the frame weldment, item 1 in drawing 7345A, from the back of the moldboard assembly by removing eight hex bolts and lock nuts. Rotate the frame to its working position and line up the eight holes in the frame with holes in the moldboard. Reassemble the frame to the moldboard with the hex bolts and lock nuts previously removed.

2. Unbolt the two bushings, item 2 in drawing 7446A, from the push frame assembly, item 3, and set aside for reinstallation. Likewise, remove clevis pins, item 4, from the two angling cylinders and unbolt the pivot bolt, item 5.

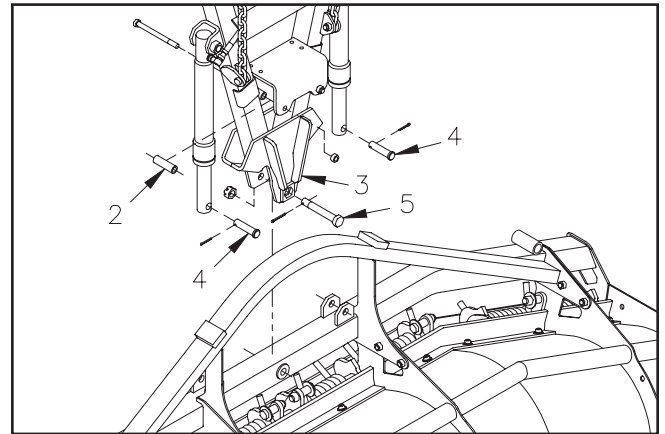

DWG NO. 7446A

Use a hoist or forklift to gently lower the push frame onto the moldboard, then reassemble the pivot bolt and clevis pins to attach the push frame to the moldboard. Reinstall the two bushings previously removed, using the original hardware.

3. Assemble side markers to the ends of the moldboard with 5/16 inch hex bolts, flat washers and lock nuts.

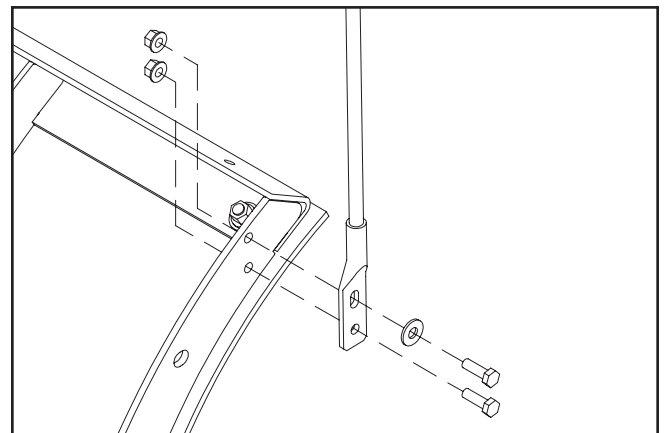

DWG NO. 7216

4. Refer to operating procedures section for attaching the plow to the loader and operating the plow. Test the plow functions in a safe area.

QUICK COUPLERS

Select and install hydraulic quick couplers and adapter fittings on the snowplow feed lines according to the size and type (i.e. flat face or poppet style) of couplers on the skid steer loader.

Hoses supplied on the snowplow have 9/16-18 JIC female swivel ends for 9/16-18 JIC male adapters.

HYDRAULIC RELIEF VALVE DIAGRAM

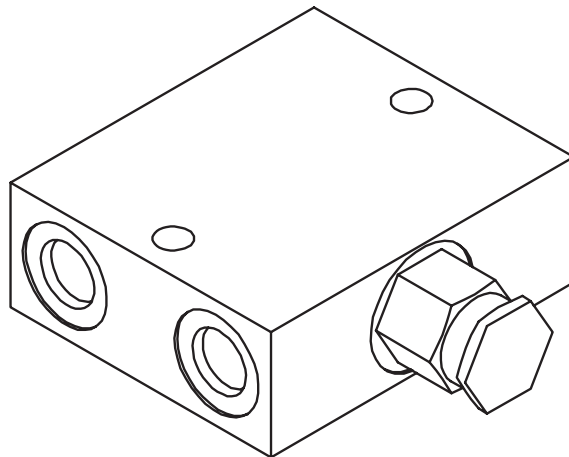
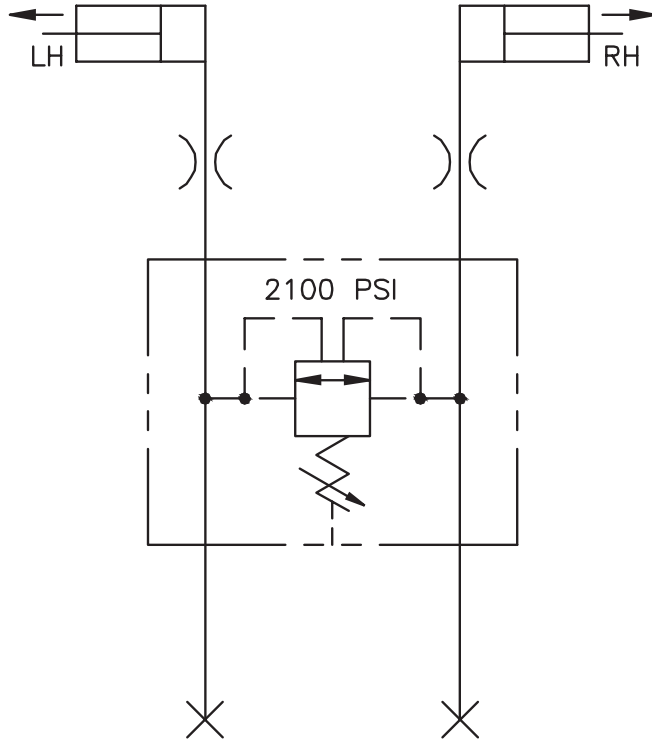

SPECIFICATIONS

	Model 2275 7 1/2' Plow	Model 2280 8' Plow	Model 2285 8 1/2' Plow	Model 2682 8' Scoop	Model 2692 9' Scoop	Model 2103 10' Plow
Blade Width	7' 6"	8'	8' 6"	8' At Trip Pin	9' At Trip Pin	10'
Plow Width Angled 30°	6' 5"	6' 10"	7' 3"	7' At Trip Pin	7' 10" At Trip Pin	8' 7"
Weight	492 lbs.	507 lbs.	542 lbs.	685 lbs.	748 lbs.	903 lbs.
Blade Height	30"					32"
Cutting Edge	3/8" x 6" 1084 Steel (Standard) 1/2" x 6" 1084 Steel (Optional)			3/8" x 6" 1084 Steel (Optional) 1/2" x 6" 1084 Steel (Optional)		1/2" x 8" 1084 Steel

WARRANTY

SKID STEER SNOWPLOW LIMITED WARRANTY

The only warranty Hiniker Company (Hiniker) gives and the only warranty that any Hiniker dealer is authorized to give on behalf of Hiniker is as follows: **(NO EMPLOYEE OR REPRESENTATIVE IS AUTHORIZED TO CHANGE THIS WARRANTY IN ANY WAY OR GRANT ANY OTHER WARRANTY.)**

Hiniker warrants to the original purchaser of a Hiniker snowplow that Hiniker will repair or replace any defects in material and workmanship that occur within one year from date of retail delivery.

Hiniker's obligation and liability under this warranty is expressly limited to repairing or replacing, at Hiniker's option, at an authorized Hiniker dealer location, the defective parts at no charge to the original purchase. **HINIKER MAKES NO OTHER WARRANTY, EXPRESS OR IMPLIED AND MAKES NO WARRANTY OF MERCHANTABILITY OR OF FITNESS FOR ANY PARTICULAR PURPOSE.**

HINIKER'S OBLIGATION UNDER THIS WARRANTY SHALL NOT INCLUDE ANY TRANSPORTATION CHARGES TO OR FROM THE AUTHORIZED HINIKER DEALER LOCATION OR ANY LIABILITY FOR INCIDENTAL, INDIRECT OR CONSEQUENTIAL DAMAGE OR DAMAGES OF ANY KIND FOR LOST PROFITS OR DELAY. If requested by Hiniker, products or parts for which a warranty claim is made are to be returned freight prepaid to our factory. Any improper use, operation beyond rated capacity, substitution of parts not approved by Hiniker Company, or any alteration or repair in such manner as in our judgment affects the product materially and adversely shall void this warranty.

Hiniker reserves the right to make improvements or changes to any of its products without notice. Such improvements or changes shall not trigger any obligation by Hiniker to update, modify or change any products previously sold by Hiniker.

HINIKER does not warrant the following:

1. Used products.
2. Any product that has been repaired, modified or altered in a way not approved by Hiniker Company.
3. Depreciation or damage caused by normal wear, lack of reasonable and proper maintenance, failure to follow Operators Manual Instructions, misuse, lack of proper protection during storage, or accident.
4. Parts replacement and service necessitated by normal wear or maintenance including, but not limited to, cutting edges, hoses, snowplow skid shoes, and hardware.
5. Paint finish damage caused by normal wear.

Hiniker does not assume any liability for any damage to a skid steer unit resulting from the attachment or use of a Hiniker snowplow. Attachment of a Hiniker snowplow to skid steer unit is at the risk of the purchaser.

It is the responsibility of the original snowplow purchaser to verify the original date of purchase.

A DELIVERY REPORT FORM must be filled out and received by Hiniker with 30 days of retail delivery at the address below to initiate the warranty coverage.

HINIKER COMPANY
58766 240th St.
P.O. Box 3407
MANKATO, MN 56002-3407
PHONE (507) 625-6621 -- FAX (507) 625-5883
www.hiniker.com

