

FOX

SKID STEER LOADER SNOW PUSHER MODELS 3696, 36120

OPERATOR'S MANUAL

DO NOT USE OR OPERATE THIS EQUIPMENT UNTIL THIS MANUAL
HAS BEEN READ AND THOROUGHLY UNDERSTOOD

PART NUMBER 27000225 Rev. A

TABLE OF CONTENTS

27000225 Rev. A

3/20

MANUALS/27000225 Rev. B

TO THE PURCHASER.....	2
SAFETY.....	3
OPERATING PROCEDURES	4-5
MAINTENANCE	6
TROUBLE SHOOTING	7
SNOW PUSHER ASSEMBLY	8-9
SPECIFICATIONS.....	10
WARRANTY	11

TO THE PURCHASER

This product is designed and manufactured to give years of dependable service when properly maintained and used for the purpose for which it is intended. Never allow anyone to operate this equipment until they fully understand the complete contents of this manual. It is the responsibility of owners who do not operate this equipment to ensure the operator is properly instructed and understands the contents of this manual. It is also the owner's responsibility to ensure that anyone operating this equipment is mentally and physically capable of so doing.

Important information is contained in this manual to help ensure safe and efficient operation.

If you have any questions about this manual, or the equipment discussed herein, contact your snow pusher dealer



This is a safety alert symbol. It alerts an operator to information concerning personal safety. Always observe and heed these instructions, otherwise death or serious injury can result.

All references to Left or Right are defined as viewing the plow from the cab of the machine.

This Operator's Manual is shipped with this equipment. Contact your dealer for additional copies.

Always obtain original Fox service parts. Substitute parts could adversely affect equipment performance and warranty.

Check that your dealer has forwarded the delivery report form along with the plow identification number because it helps maintain maximum service and warranty benefits. This does not put you on any mailing list, and information thereon is not available to others.

Your pusher's identification number plate is at location (1) in the following illustration.

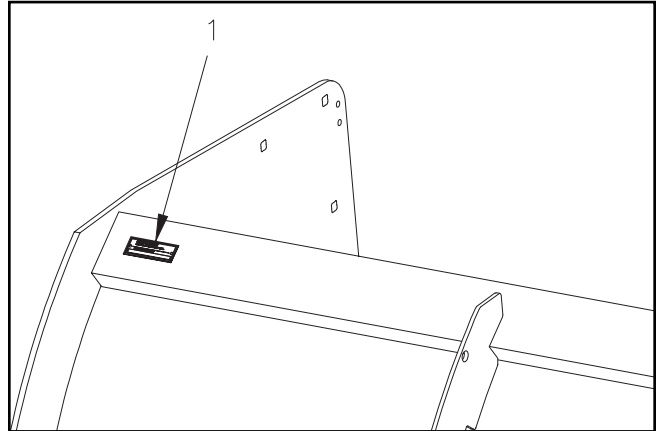

DWG NO. 7497

Record the following information for later reference when obtaining service parts:

Purchase Date _____

Purchaser's Name _____

Dealer's Name _____

Machine I.D. No. _____

SAFETY



This is a safety alert symbol. It alerts an operator to information concerning personal safety. Always observe and heed these symbols and instructions, otherwise death or serious injury can result.

Operator safety is a principle concern in equipment design and distribution. However, many accidents occur because a few seconds of thought, and a more careful approach to handling, were ignored. Accidents can be avoided by knowing and following the precautions cited in this manual.

GENERAL SAFETY

1. Read this manual thoroughly. Make sure the operator understands it and knows how to operate this equipment safely. This equipment can kill or injure an untrained or careless operator and bystanders. If you sell this equipment, ensure the new owner acknowledges receipt of this manual.
2. This manual **Does Not** instruct the operation or maintenance of the skid steer loader. Obtain training on control and function of the skid steer loader from your loader dealer.
3. This pusher is intended for pushing snow only. Pushing gravel, rocks, etc., or using the pusher for any purpose other than pushing snow could result in harm to the operator or bystanders or cause damage to the pusher and will void the warranty.
4. Do not attempt to handle or service this equipment, or direct others to do the same, unless you know how to do it safely and have the proper tools for the job.
5. Do not service or otherwise handle a pusher in the raised position unless it is securely blocked against unexpected falling.
6. Keep hands, feet, hair, and clothing away from moving parts.
7. Do not alter the equipment to the extent of compromising safety or performance.

BEFORE OPERATION

1. Discipline yourself to visually check for worn, damaged or cracked parts before starting use. Replace these with genuine Fox service parts.
2. Escaping hydraulic oil under pressure can penetrate the skin, causing serious injury.

Do not use your hand to check for leaks. Use a piece of paper or cardboard to find suspected leaks. Tighten all connections before pressurizing hydraulic lines. If fluid is injected into the skin, get medical attention immediately to prevent serious infection.

3. Check all controls and operating functions of the machine in a safe area before starting to work.

DURING OPERATION

1. Always wear the seat belt and lower the seat bar, if equipped, when operating the loader.
2. Make sure all controls are in the neutral position before starting the loader.
3. Ensure everyone is clear of the machine, especially away from blind areas of the operator, before actuating hydraulics or operating this equipment.
4. Do not push snow at excessively high speeds.
5. Avoid hitting objects that will damage your pusher.
6. Set the brakes and stop the loader's engine before adjusting or servicing your pusher

AFTER OPERATION

1. Park the pusher on a solid, level surface.

OPERATING PROCEDURES



IMPORTANT: To prevent damage to pusher components, skid steer loaders with a “High Flow/Low Flow” hydraulic system must be operated in the Low Flow setting when the pusher is attached.

ATTACHING THE PUSHER

Mount the pusher on the skid steer loader by driving the loader into the mount frame, then set the brakes and relieve hydraulic pressure before exiting the cab. Secure the pusher frame to the loader as instructed in the loader manual. Make sure all latches are fully locked in place to prevent the pusher from detaching, (drawing 7498).

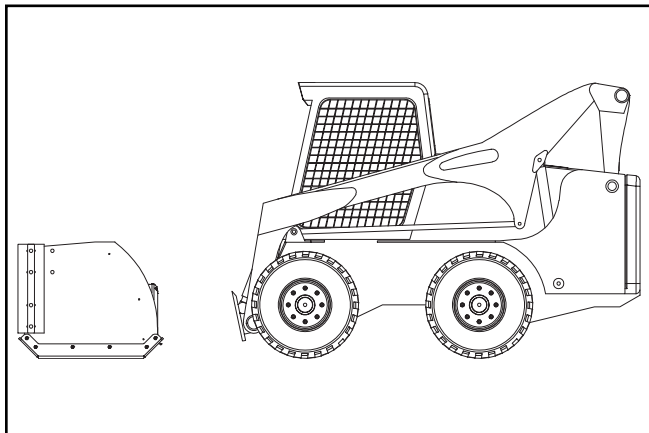

DWG NO. 7498

Test the lifting functions in a safe area before using the pusher.

CONTROLLING THE PUSHER FUNCTIONS

Raise and lower the pusher by operating the loader arms as you would for any other attachment. Avoid tipping the mount plate forward to apply down pressure on the pusher.

TRANSPORTING THE PUSHER

Raise the pusher to a position where it does not block your view forward. Transport the pusher with hydraulic flow off or in neutral to prevent accidental lowering of the pusher. Never adjust the pusher position while driving.

PUSHING SNOW



WARNING: Always wear the seat belt and lower the seat bar, if equipped, when pushing snow. Sudden contact with a hidden object can result in serious personal injury.

Inspect areas to be cleared of snow before snowfall for potential hazards, and mark obstructions with stakes that will be seen when snow covers the ground. Identify any emergency equipment and utility outlets that may need to be cleared in the event of a storm. Prepare a plan beforehand for clearing snow from tight or enclosed areas and locate sites for stacking snow.

Set the loader lift arms into the float mode so the pusher can follow the contour of the ground and clean up low areas while pushing snow.

Always push snow as it is accumulating. Wet snow may weigh about 12 pounds per cubic foot. The weight of snow being pushed by your pusher may increase to several tons.

Allowing snow depth to grow to unmanageable levels can cause difficult removal problems and can be costly in terms of wear on equipment.



WARNING: Serious personal injury can result from pushing snow at excessive speeds, as well as costly damage to equipment and property, if an obstruction is encountered while pushing snow. Do not exceed 10 mph while pushing snow.

When pushing very deep snow, it may be necessary to raise the blade and shear off layers of snow until a working area is cleared. Work small areas in multiple passes to push snow to outer edges. Generally, 6 inch snow can be pushed with the entire blade width; 9 inch snow with 3/4 of the blade width; 12 inch snow with 1/2 of the blade width. Local conditions will determine how much work can be done before stalling or getting stuck.

REMOVING THE PUSHER

Park the pusher on a solid level surface with the blade straight across the loader.

Lower the blade to the ground, relieve hydraulic pressure and set the brakes on the loader.

Unlatch the attachment mechanism at the front of the loader. Slowly drive the loader back away from the pusher.

MAINTENANCE



WARNING: Do not service or otherwise handle a pusher in the raised position unless it is securely blocked against unexpected failing.

Dependable snow pusher operation is the result of following good maintenance procedures. Inspect your pusher frequently to ensure that all parts are working smoothly, and develop a schedule for maintenance at required intervals.

GENERAL

Wash salt and dirt off the pusher before storage.

MECHANICAL COMPONENTS

Prior to the operation of a new snow pusher, or one which has been stored, inspect all hardware and verify proper torque on all bolts and nuts in accordance with the recommended torque specifications.

GRADE 5 TYPE B & F LOCK NUT TORQUES

Size	Ft-lbs.	N-m
5/16"	13-18	17-25
3/8"	23-33	31-44
1/2"	58-82	79-112
5/8"	117-165	158-223

GRADE 5 BOLT TORQUES*

Size	Ft-lbs.	N-m
1/4"	8-12	11-16
3/8"	29-41	39-56
1/2"	73-103	99-140
5/8"	146-206	198-279

*applications without lock nuts.

Loose bolts can cause hole elongation and part failure resulting in dangerous operating conditions and equipment breakdown.

Check all hardware periodically during operation and keep tightened to specified torques. Replace worn bolts and lock nuts with grade 5 bolts and equivalent type B or type F lock nuts. Type B lock nuts are plain hex; type F lock nuts are flanged hex.

Inspect wear of the cutting edge before every snow removal season and frequently throughout the season.

TROUBLE SHOOTING

GENERAL

- | | |
|---|--|
| <p>1. Check for worn or loose bolts on blade and wear shoes.</p> <p>2. Check for cracks in the welds and frame components.</p> <p>3. Check for worn components; blade and wear shoes.</p> | <p>4. Check skid steer quick attachment plate for proper fit-up.</p> <p>5. Check that all safety decals are in good shape and visible.</p> |
|---|--|

PROBLEM	POSSIBLE CAUSE	REMEDY
<p>1. Pusher does not clean-up snow from low areas.</p>	<p>A. Rubber blade not adjusted to proper height.</p>	<p>A. Adjust rubber blade to proper height.</p>
<p>Pusher does not clean-up snow from low areas.</p>	<p>B. Loader arms not in float position.</p>	<p>B. Put loader arms in float position</p>
<p>2. Wear shoes are getting thin.</p>	<p>A. Too much down pressure on pusher.</p>	<p>A. Put loader arms in float position.</p> <p>B. Install new wear shoes</p>
<p>3. Rubber scraper blade not touching ground.</p>	<p>A. Rubber Scraper Blade worn out.</p>	<p>A. Flip blade over.</p> <p>B. Install new blade.</p>

SNOW PUSHER ASSEMBLY

GENERAL INFORMATION



WARNING: To prevent personal injury or death, be certain to keep clear of any parts that may drop when removing bundling straps, wires or brackets. Support heavy sections with hoist or blocks before removing wires or straps.

SNOW PUSHER ASSEMBLY

The snow pusher comes fully assembled when it leaves the Fox facility, but it is always a good practice to recheck all the assembled parts to ensure that none of the fasteners have loosened during shipment.

SCRAPER BLADE ADJUSTMENT

The simplicity of the snow pusher's design lends itself to only minor adjustments. The rubber scraper blade is the only item that will need to be adjusted periodically during seasonal operations. This adjustment should only be done when the rubber scraper blade is above 60 degrees Fahrenheit. This temperature is necessary to ensure that the rubber will slightly "deform" during tightening of the clamping bolts.

If the blade is too cold the rubber will not "deform" and blade may loosen under cold weather operations. The blade will need to be adjusted lower when the pusher shows signs of leaving snow behind or the scraping edge of the blade becomes rough and jagged. When properly adjusted the blade should be approximately 1/8"- 1/4" below the bottom of the hardened steel wear shoes that are attached to the side plates.

Once the blade is adjusted to the proper depth, re-tighten the bolting strip until the rubber scraper blade bulges above and below the bolting strip.

BREAKING IN A NEW SCRAPER BLADE

When the rubber scraper blade is new, it will be square on the edge that comes in contact with the ground.

For the pusher blade to work at it's peak performance, the edge of the blade will need to become fully engaged with the ground over the full thickness of the blade. This is easily accomplished by wearing the blade flush with the ground. This can be done by adjusting the "leading corner" of the blade flush with the bottom of the wear shoes, (drawing 7499).

Initially, this may cause the pusher to want to bounce or chatter while in operation but, over time the ground contact with the blade will wear the rubber blade flush with the mating surface of the ground.

Once the blade is worn flush with the ground, the performance of the pusher will be greatly enhanced. This blade has a symmetric design which allows the operator to flip the blade over to the opposite side once it is worn out on one side.

This allows the operator to obtain twice the life out of the rubber scraper blade. Note: blade adjustments should only be done when the rubber scraper blade is above 60 degrees Fahrenheit.

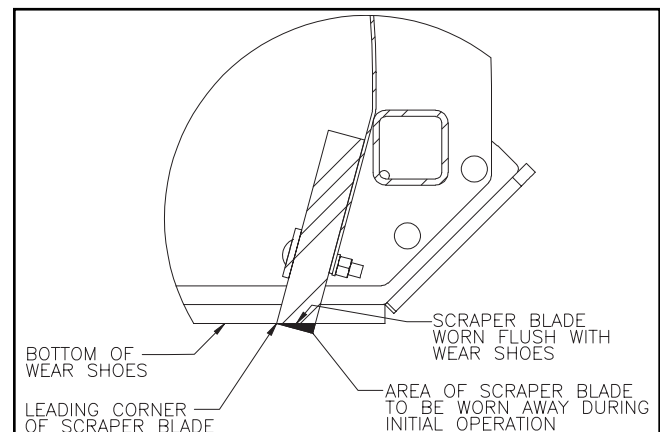

DWG NO. 7499

PULL BACK ASSEMBLY

The Pull Back Assembly consists of one main scraper blade assembly and two side blade assemblies.

The main scraper blade assembly bolts on the inside of the snow pusher side plates. The two side blade assemblies bolt on to the outside of both the left and right snow pusher side plates, (drawing 7500).

SCRAPER BLADE ADJUSTMENT

The simplicity of the snow pusher's design lends itself to only minor adjustments. The rubber pull back blade will need to be adjusted periodically during seasonal operations. This adjustment should only be done when the rubber pull back blade is above 60 degrees Fahrenheit. This temperature is necessary to ensure that the rubber will slightly "deform" during tightening of the clamping bolts (drawing 7501).

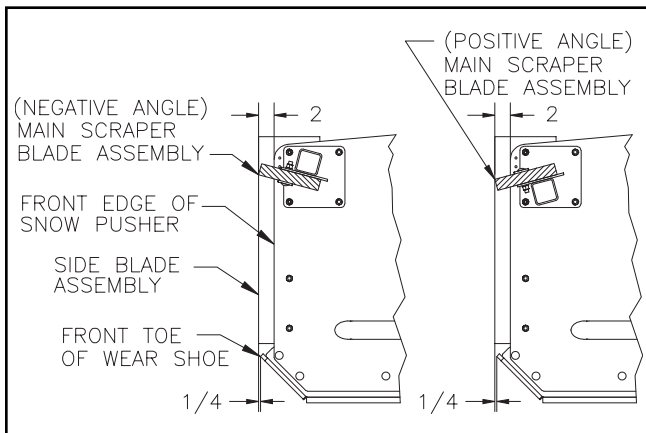

DWG NO. 7501

If the blade is too cold the rubber will not "deform" and blade may loosen under cold weather operations.

Once the blade is adjusted to the proper depth, re-tighten the bolting strip until the rubber scraper blade bulges above and below the bolting strip.

BREAKING IN A NEW SCRAPER BLADE

When the rubber scraper blade is new, it will be square on the edge that comes in contact with the ground.

For the pull back blade to work at it's peak performance, the edge of the blade will need to become fully engaged with the ground over the full thickness of the blade. This is easily accomplished by wearing the blade flush with the ground. This can be done by adjusting the "leading corner" of the blade flush with the bottom of the wear shoes.

Initially, this may cause the pusher to want to bounce or chatter while in operation but, over time the ground contact with the blade will wear the rubber blade flush with the mating surface of the ground.

Once the blade is worn flush with the ground, the performance of the pusher will be greatly enhanced. This blade has a symmetric design which allows the operator to flip the blade over to the opposite side once it is worn out on one side.

This allows the operator to obtain twice the life out of the rubber pull back blade. Note: blade adjustments should only be done when the rubber pull back blade is above 60 degrees Fahrenheit.

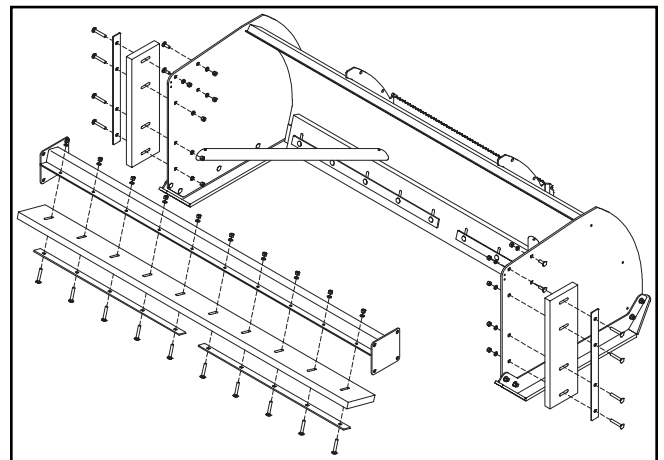

DWG NO. 7500

SPECIFICATIONS

	Model 3696	Model 36120
Overall Width	8'	10'
Overall Height	36"	36"
Overall Depth	36"	36"
Weight Pusher (Only)	836 lbs.	917 lbs.
Weight Pusher & Pullback	1031 lbs.	1140 lbs.
Rubber Scraper Blade	1 1/2" Thick x 8" Wide	1 1/2" Thick x 8" Wide
Replaceable Wear Shoes	AR 400 Material	AR 400 Material
Moldboard	10 Gauge	10 Gauge
Side Plates	3/8" Thick	3/8" Thick
Universal Skid Steer Mount	Yes	Yes

WARRANTY

SKID STEER SNOW PUSHER LIMITED WARRANTY

The only warranty Fox gives and the only warranty that any Fox dealer is authorized to give on behalf of Fox is as follows: **(NO EMPLOYEE OR REPRESENTATIVE IS AUTHORIZED TO CHANGE THIS WARRANTY IN ANY WAY OR GRANT ANY OTHER WARRANTY.)**

Fox warrants to the original purchaser of a Fox snow pusher that Fox will repair or replace any defects in material and workmanship that occur within one year from date of retail delivery.

Fox's obligation and liability under this warranty is expressly limited to repairing or replacing, at Fox's option, at an authorized Fox dealer location, the defective parts at no charge to the original purchase. **FOX MAKES NO OTHER WARRANTY, EXPRESS OR IMPLIED AND MAKES NO WARRANTY OF MERCHANTABILITY OR OF FITNESS FOR ANY PARTICULAR PURPOSE.**

FOX'S OBLIGATION UNDER THIS WARRANTY SHALL NOT INCLUDE ANY TRANSPORTATION CHARGES TO OR FROM THE AUTHORIZED FOX DEALER LOCATION OR ANY LIABILITY FOR INCIDENTAL, INDIRECT OR CONSEQUENTIAL DAMAGE OR DAMAGES OF ANY KIND FOR LOST PROFITS OR DELAY. If requested by Fox, products or parts for which a warranty claim is made are to be returned freight prepaid to our factory. Any improper use, operation beyond rated capacity, substitution of parts not approved by Fox, or any alteration or repair in such manner as in our judgment affects the product materially and adversely shall void this warranty.

Fox reserves the right to make improvements or changes to any of its products without notice. Such improvements or changes shall not trigger any obligation by Fox to update, modify or change any products previously sold by Fox.

Fox does not warrant the following:

1. Used products.
2. Any product that has been repaired, modified or altered in a way not approved by Fox.
3. Depreciation or damage caused by normal wear, lack of reasonable and proper maintenance, failure to follow Operators Manual Instructions, misuse, lack of proper protection during storage, or accident.
4. Parts replacement and service necessitated by normal wear or maintenance including, but not limited to, cutting edges, hoses, snowplow skid shoes, and hardware.
5. Paint finish damage caused by normal wear.

Fox does not assume any liability for any damage to a skid steer unit resulting from the attachment or use of a Fox snow pusher. Attachment of a Fox snow pusher to skid steer unit is at the risk of the purchaser.

It is the responsibility of the original snow pusher purchaser to verify the original date of purchase.

A DELIVERY REPORT FORM must be filled out and received by Fox with 30 days of retail delivery at the address below to initiate the warranty coverage.

FOX
58766 240th St.
MANKATO, MN 56001
PHONE (507) 625-6621 -- FAX (507) 625-5883
www.hiniker.com